



Electronics Merit Badge

Troops 344 and 9344
Pemberville, OH

Electronics Merit Badge Requirements



1. Describe the safety precautions you must exercise when using, building, altering, or repairing electronic devices.
2. Do the following:
 - a. Draw a simple schematic diagram. It must show resistors, capacitors, and transistors or integrated circuits. Use the correct symbols. Label all parts.
 - b. Tell the purpose of each part.
3. Do the following:
 - a. Show the right way to solder and desolder.
 - b. Show how to avoid heat damage to electronic components.
 - c. Tell about the function of a printed circuit board. Tell what precautions should be observed when soldering printed circuit boards.

Electronics Merit Badge Requirements



4. Do the following:

- a. Discuss each of the following with your merit badge counselor:
 1. How to use electronics for a control purpose
 2. The basic principles of digital techniques
 3. How to use electronics for three different audio applications
- b. Show how to change three decimal numbers into binary numbers, and three binary numbers into decimal numbers.
- c. Choose ONE of the following three projects. For your project, find or create a schematic diagram. To the best of your ability, explain to your counselor how the circuit you built operates.
 1. A control device
 2. A digital circuit
 3. An audio circuit

Electronics Merit Badge Requirements



5. Do the following:

- a. Show how to solve a simple problem involving current, voltage, and resistance using Ohm's law.
- b. Tell about the need for and the use of test equipment in electronics. Name three types of test equipment. Tell how they operate.
- c. Demonstrate to your counselor how to read the colored bands of a resistor to determine its resistance value.

6. Find out about three career opportunities in electronics that interest you. Discuss with and explain to your counselor what training and education are needed for each position.

BASIC CONCEPTS OF ELECTRICITY



Electrical
Charge

Current

Voltage

Resistance

Conductor/
Insulator

Electric
Circuit

Basic Concepts of Electricity

- When beginning to explore the world of electricity and electronics, it is vital to start by understanding the basics of voltage, current, and resistance.
- These are the three basic building blocks required to manipulate and utilize electricity.

Electricity is like a water hose

Voltage

Volts (V)



Current

Amps (A or I)

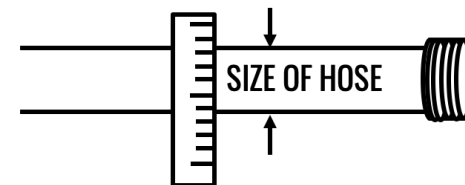

Resistance

Ohms (R or Ω)



FREEING
ENERGY



Electrical Charge

- Electricity is the movement of electrons. Electrons create charge, which we can harness to do work. Your lightbulb, stereo, phone, etc., are all harnessing the movement of the electrons in order to do work. They all operate using the same basic power source: the movement of electrons.
- The three basic principles can be explained using electrons, or more specifically, the charge they create:
 - **Voltage** is the difference in charge between two points.
 - **Current** is the rate at which charge is flowing.
 - **Resistance** is a material's tendency to resist the flow of charge (current).
- So, when we talk about these values, we're really describing the movement of charge, and thus, the behavior of electrons. A circuit is a closed loop that allows charge to move from one place to another. Components in the circuit allow us to control this charge and use it to do work.

Voltage

- We define voltage as the amount of potential energy between two points on a circuit. One point has more charge than another. This difference in charge between the two points is called voltage.
- The unit "volt" is named after the Italian physicist Alessandro Volta who invented what is considered the first chemical battery. Voltage is represented in equations and schematics by the letter "V".



Voltage

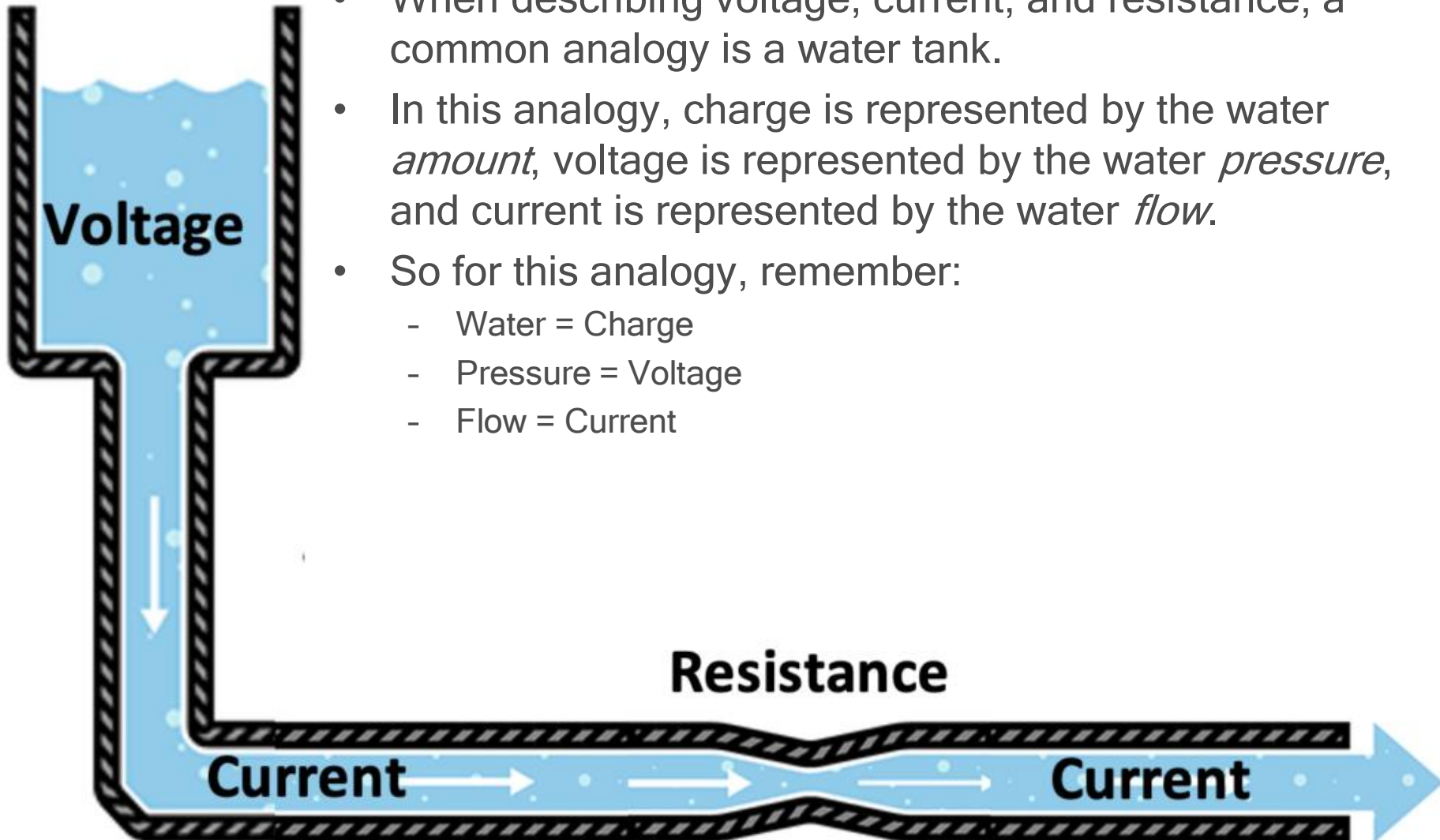

- When describing voltage, current, and resistance, a common analogy is a water tank.
- In this analogy, charge is represented by the water *amount*, voltage is represented by the water *pressure*, and current is represented by the water *flow*.
- So for this analogy, remember:
 - Water = Charge
 - Pressure = Voltage
 - Flow = Current

Voltage

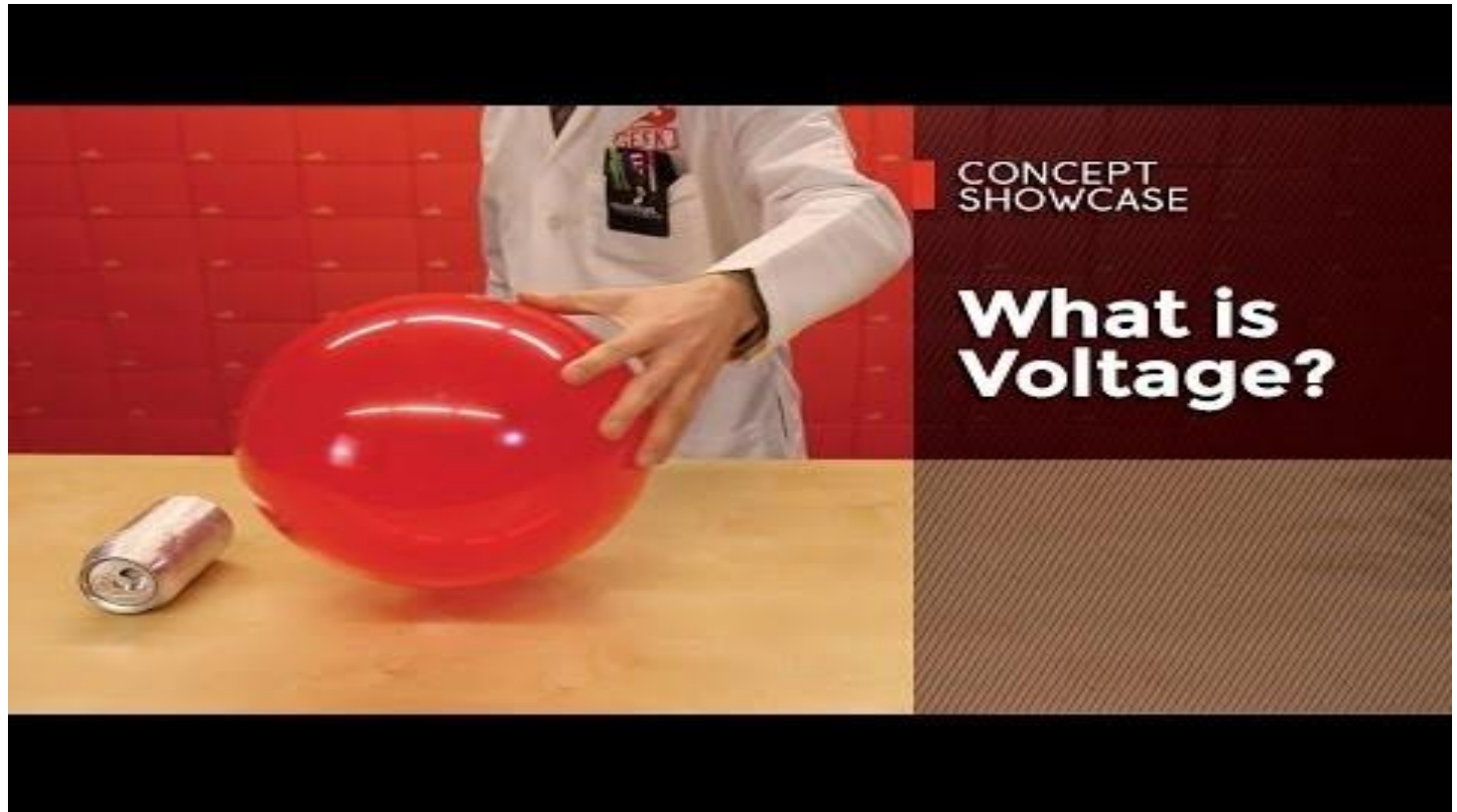

Click on the above video to better understand voltage.

Voltage

- Consider a water tank at a certain height above the ground. At the bottom of this tank there is a hose.
- The pressure at the end of the hose can represent voltage. The water in the tank represents charge. The more water in the tank, the higher the charge, the more pressure is measured at the end of the hose.
- We can think of this tank as a battery, a place where we store a certain amount of energy and then release it.
- If we drain our tank a certain amount, the pressure created at the end of the hose goes down. We can think of this as decreasing voltage, like when a flashlight gets dimmer as the batteries run down.

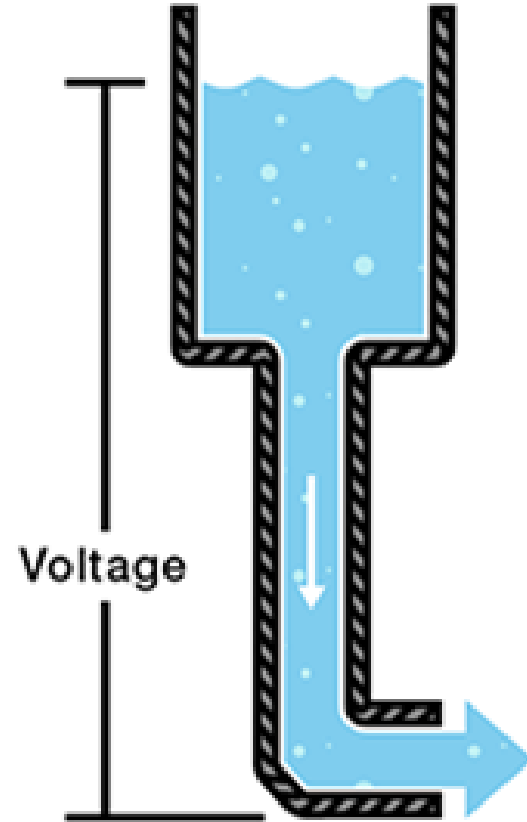

Current

- We can think of the amount of water flowing through the hose from the tank as current. The higher the pressure, the higher the flow, and vice-versa.
- With water, we would measure the volume of the water flowing through the hose over a certain period of time.
- With electricity, we measure the amount of charge flowing through the circuit over a period of time.
- Current is measured in Amperes (usually just referred to as "Amps").
- An ampere is defined as 6.241×10^{18} electrons (1 Coulomb) per second passing through a point in a circuit.
- Amps are represented in equations by the letter "I".

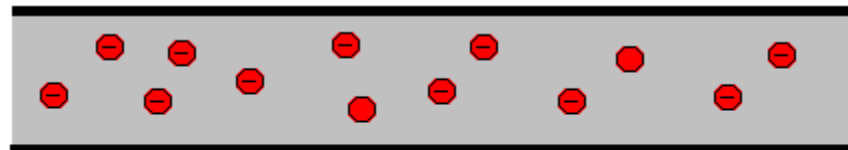

Few Electrons Flowing = Low Amps

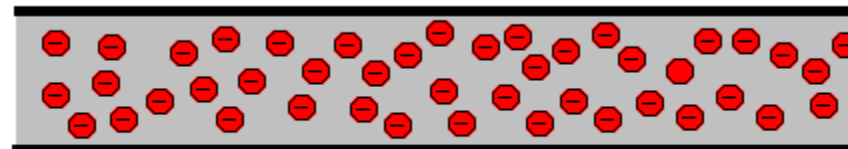

Many Electrons Flowing = High Amps

Current



Click on the above video to better understand current.

Current

- Let's say now that we have two tanks, each with a hose coming from the bottom. Each tank has the exact same amount of water, but the hose on one tank is narrower than the hose on the other.

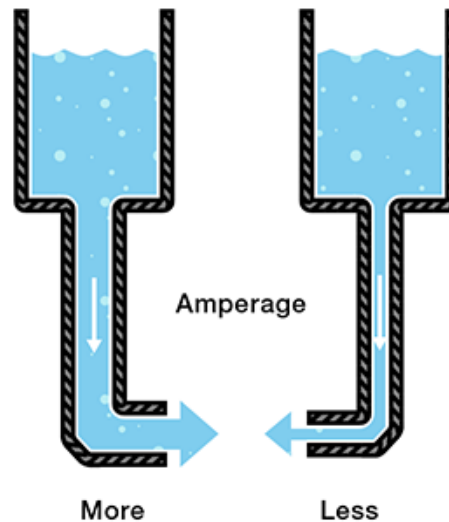

- We measure the same amount of pressure at the end of either hose, but when the water begins to flow, the flow rate of the water in the tank with the narrower hose will be less than the flow rate of the water in the tank with the wider hose. In electrical terms, the current through the narrower hose is less than the current through the wider hose.

Current

- If we want the flow to be the same through both hoses, we have to increase the amount of water (charge) in the tank with the narrower hose.

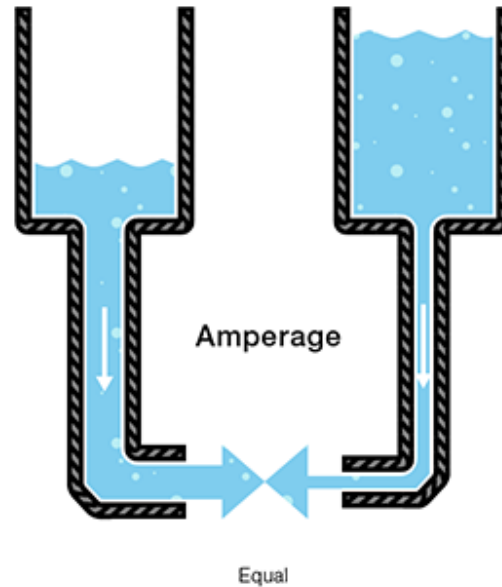

- This increases the pressure (voltage) at the end of the narrower hose, pushing more water through the tank. This is analogous to an increase in voltage that causes an increase in current.

Resistance

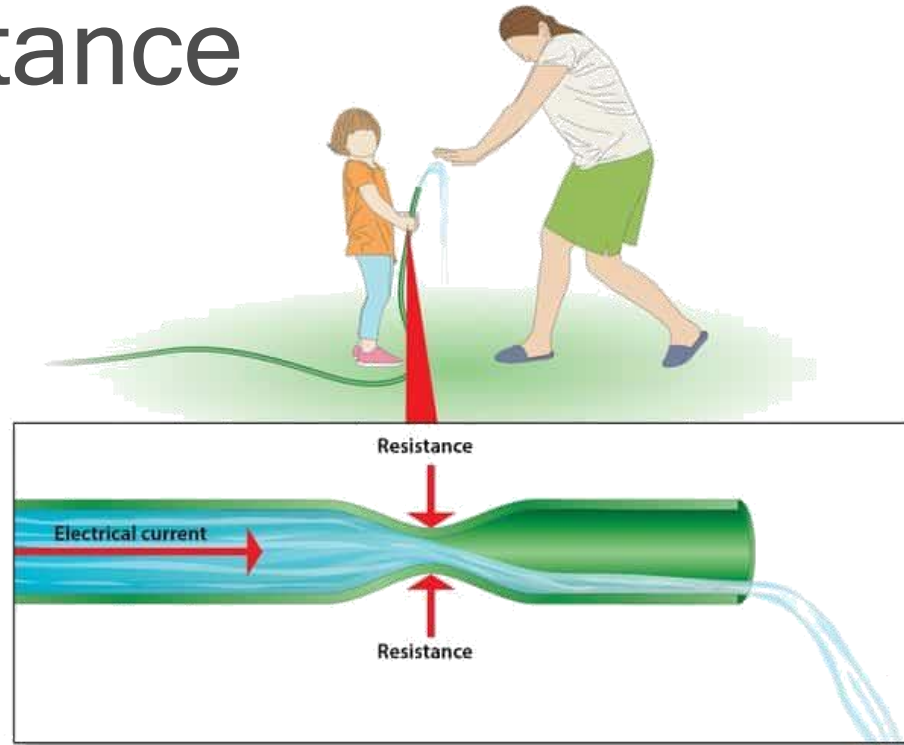

- Now we're starting to see the relationship between voltage and current. But there is a third factor to be considered here: the width of the hose. In this analogy, the width of the hose is the resistance. This means we need to add another term to our model:
 - Water = Charge (measured in Coulombs)
 - Pressure = Voltage (measured in Volts)
 - Flow = Current (measured in Amperes, or "Amps" for short)
 - Hose Width = Resistance

Resistance

- Consider again our two water tanks, one with a narrow pipe and one with a wide pipe.

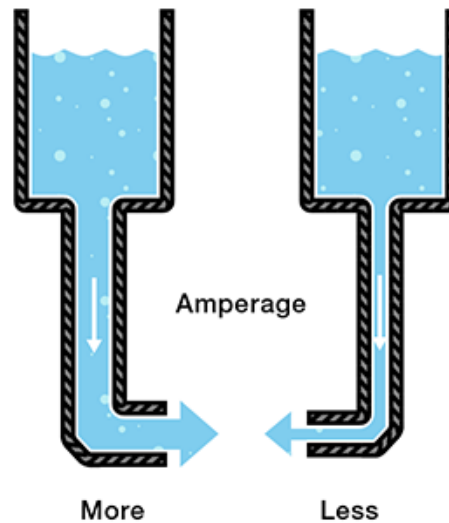

- It stands to reason that we can't fit as much volume through a narrow pipe than a wider one at the same pressure. This is resistance. The narrow pipe "resists" the flow of water through it even though the water is at the same pressure as the tank with the wider pipe.

Resistance

- In electrical terms, this is represented by two circuits with equal voltages and different resistances. The circuit with the higher resistance will allow less charge to flow, meaning the circuit with higher resistance has less current flowing through it.

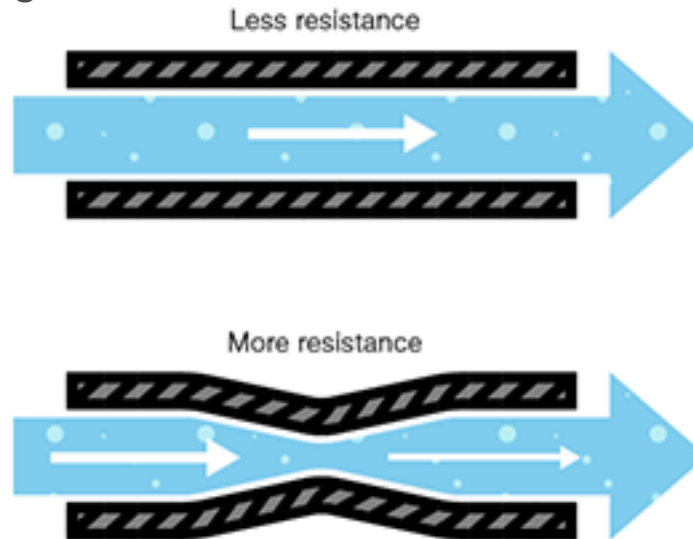

- In electrical terms, this is represented by two circuits with equal voltages and different resistances. The circuit with the higher resistance will allow less charge to flow, meaning the circuit with higher resistance has less current flowing through it.

Resistance

- This brings us to Georg Ohm. Ohm defines the unit of resistance of "1 Ohm" as the resistance between two points in a conductor where the application of 1 volt will push 1 ampere, or 6.241×10^{18} electrons. This value is usually represented in schematics with the Greek letter Ω (omega).



Georg Ohm

Ohms Law



Click on the above video to better understand Ohms Law.

Ohms Law

- Combining the elements of voltage, current, and resistance, Ohm developed the formula below which is known as Ohm's Law:

$$V = I \cdot R$$

- Where
 - V = Voltage in volts
 - I = Current in amps
 - R = Resistance in ohms

OHM'S LAW

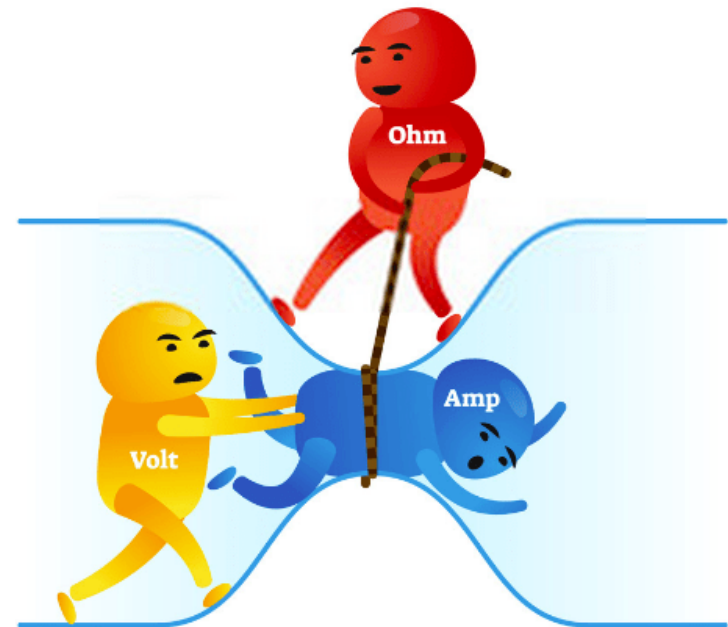

Ohms Law

- Let's say, for example, that we have a circuit with the potential of 1 volt, a current of 1 amp, and resistance of 1 ohm. Using Ohm's Law we can say:

$$1V = 1A \cdot 1\Omega$$

- Let's say this represents our tank with a wide hose. The amount of water in the tank is defined as 1 volt and the "narrowness" (resistance to flow) of the hose is defined as 1 ohm. Using Ohms Law, this gives us a flow (current) of 1 amp.

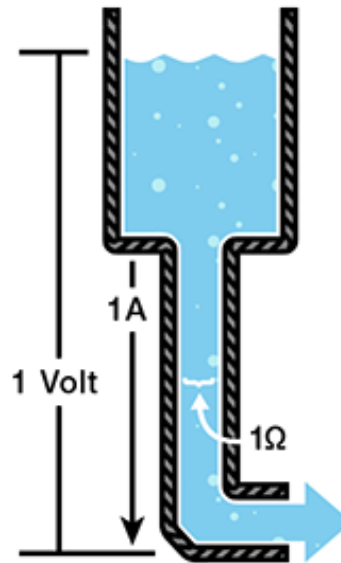

Ohms Law

- Using this analogy, let's now look at the tank with the narrow hose. Because the hose is narrower, its resistance to flow is higher. Let's define this resistance as 2 ohms. The amount of water in the tank is the same as the other tank, so, using Ohm's Law, our equation for the tank with the narrow hose is

$$1V = ?A \cdot 2\Omega$$

- But what is the current? Because the resistance is greater, and the voltage is the same, this gives us a current value of 0.5 amps:

$$1V = 0.5A \cdot 2\Omega$$

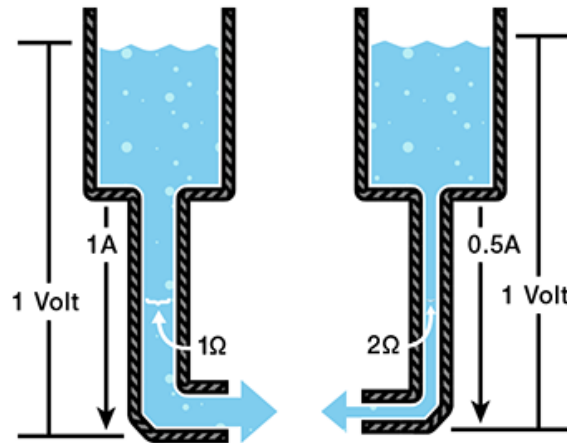

- So, the current is lower in the tank with higher resistance.

Ohms Law

- Now we can see that if we know two of the values for Ohm's Law, we can solve for the third.

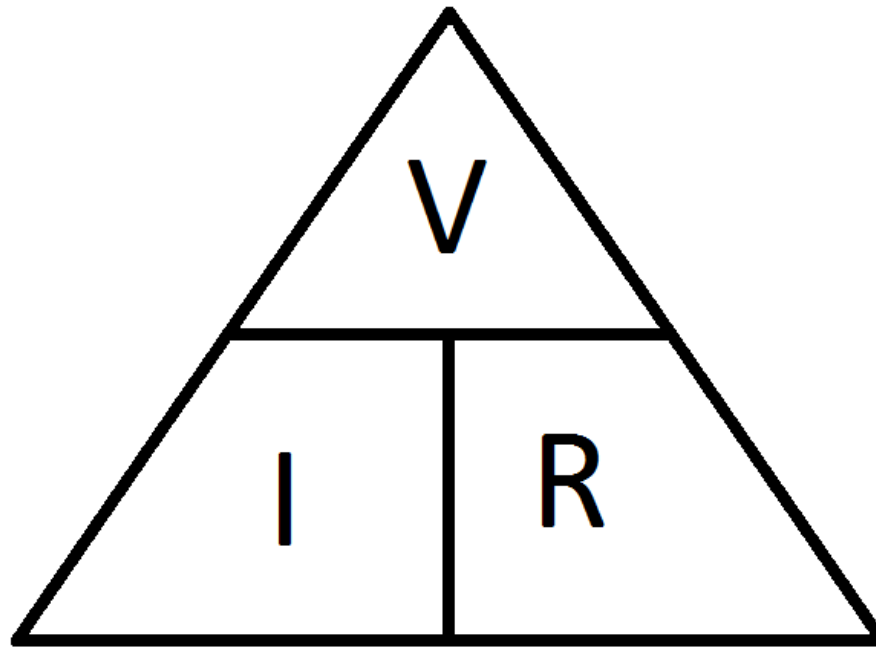

$$I = V/R$$

$$V = IR$$

$$R = V/I$$

Power - Water Analogy

- In electronics, power = current x voltage.
- The unit for power is Watts.
- The symbol for power is W.
- In our water analogy, power equals water flow x pressure.
- You can see from the picture that more water flow will mean more force, and more pressure will mean more force.



Conductors and Insulators

- Conductors

- Act as a path for electrons to flow.
- Most metals are conductors.
- Metal is used for electrical cables and wires.
- Gold, silver, copper and aluminum are good conductors because they have a lot of free electrons.

- Insulators

- Prevent the flow of electrons.
- Plastics, glass, and ceramics are good insulators because they don't have many free electrons.
- Insulators are used as the jacket on wires and cables to protect people from electrical shock and prevent 'short circuits'.

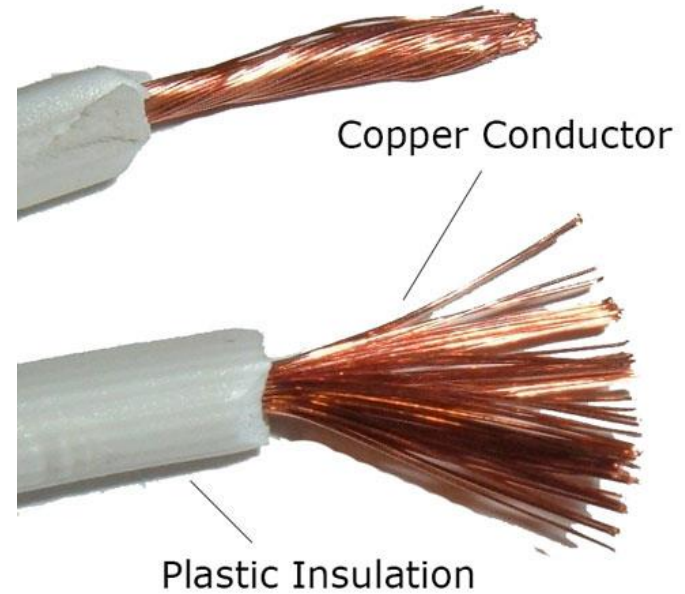

Types of Electricity

Static Electricity

- Static electricity is usually created when materials are pulled apart or rubbed together, causing positive (+) charges to collect on one material and negative (-) charges on the other surface.
- Sparks may result!
- Examples of static electricity:
 - Lightning.
 - Combing hair.
 - Walking across carpet and getting shocked.

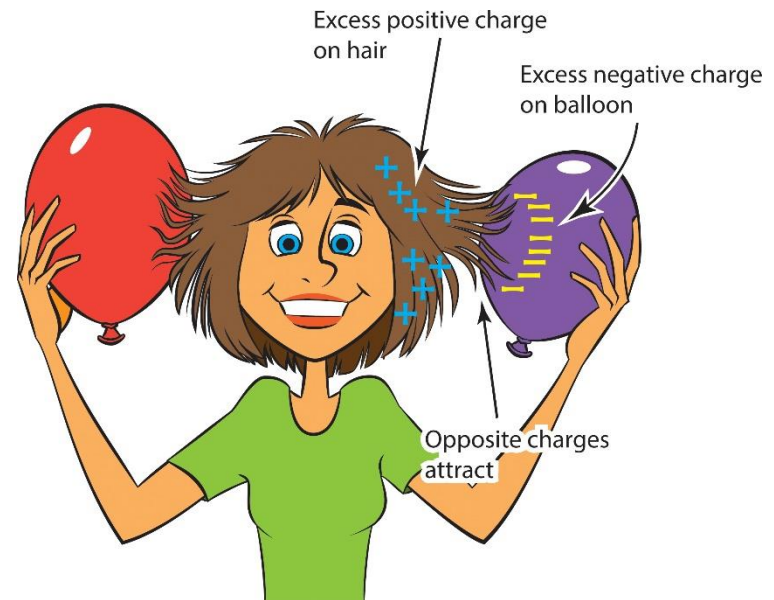

Types of Electricity

Current Electricity.

- Current is the rate of flow of electrons that is produced by moving electrons and it is measured in amperes.
- Unlike static electricity, current electricity must flow through a conductor, usually copper wire.
- There are two main kinds of electric current,
 - Direct Current (DC)
 - Alternating Current(AC).

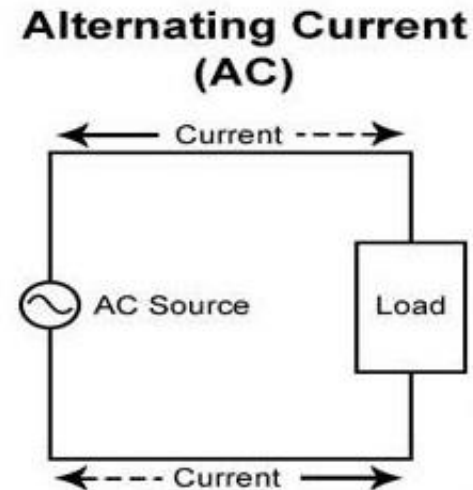
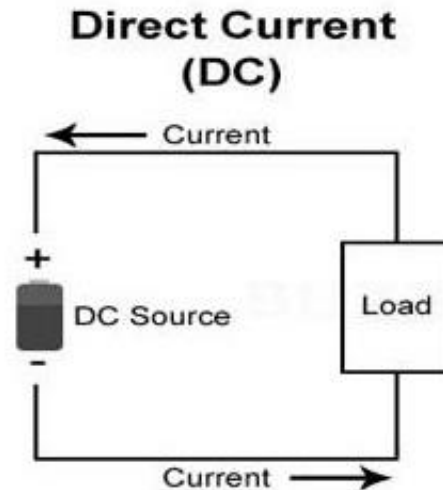

Types of Electricity

Direct Current (DC)

- Type of electricity used in most electronics we have today.
- Current only flows in one direction (not both directions, like AC).
- Examples of DC usage:
 1. Cell phones
 2. Laptop computers
 3. Tablets
 4. Remote Controls
 5. Flashlights
 6. Toys
 7. Anywhere you use a battery for power.

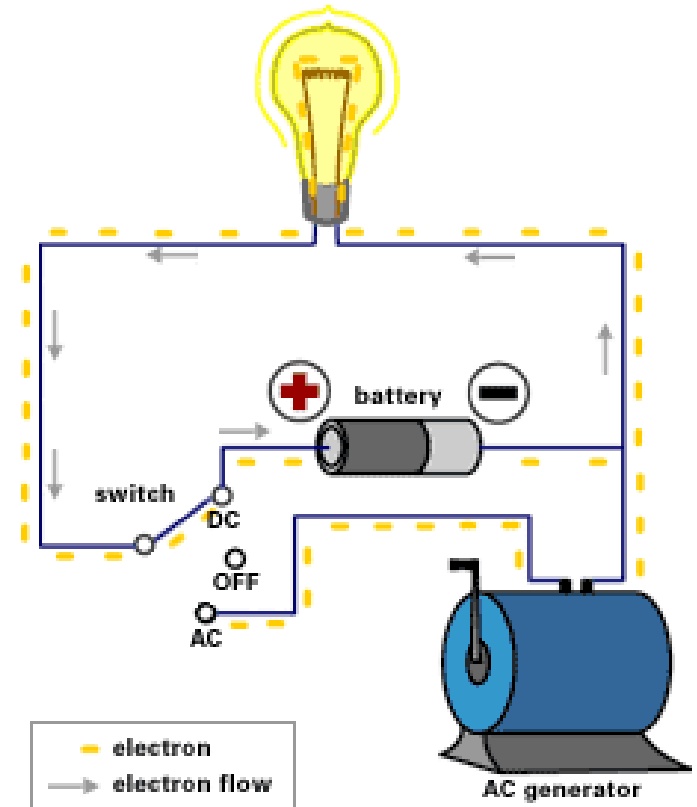

Types of Electricity

Alternating Current (AC)

- The common form of electricity generated by Power Plants for homes and industry.
- The direction of AC Current is reversed 60 times per second in the USA; 50 times per second in many other parts of the world.
- Examples of AC usage:
 1. Kitchens: Stoves, ovens, mixer, etc.
 2. Computers (the plug)
 3. Lights in house
 4. Home air conditioners.

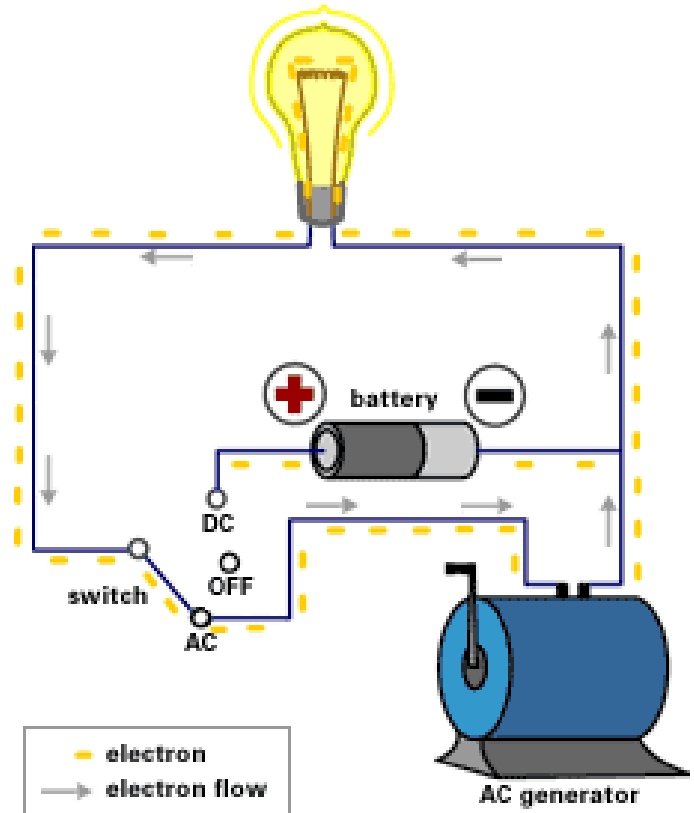

Requirement 1



Describe the safety precautions you must exercise when using, building, altering, or repairing electronic devices



Safety Precautions

- Safety first! Electronics is a potentially dangerous hobby.
- Any circuit that works with 120 VAC power from an electrical outlet is especially dangerous and could potentially kill you.
- Here are some safety guidelines to keep you safe as you work:
 1. Never work on a circuit while power is applied.
 2. Do not connect power to a circuit until the circuit is finished and you have carefully checked your work.
 3. If you smell anything burning, immediately disconnect the power and examine your circuit to find out what went wrong.
 4. Keep your work area dry.
 5. Always wear safety goggles.



Safety Precautions (cont.)

6. Be careful around large capacitors; they can continue to hold voltage long after they are disconnected from power.
7. Be especially careful when you solder because a hot soldering iron can easily burn you.
8. Always work in a well-ventilated space.
9. Never put water on an electrical fire. Use a Class C Fire Extinguisher (rated for electrical fires).
10. Have safety equipment such as a first-aid kit, and a phone nearby.



Requirement 2



Do the following:

- Draw a simple schematic diagram. It must show resistors, capacitors, and transistors or integrated circuits, Use the correct symbols. Label all parts.
- Tell the purpose of each part.

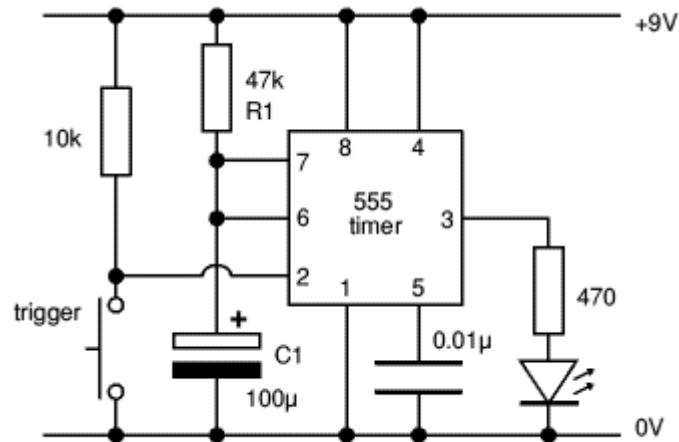

How to Draw a Schematic Diagram

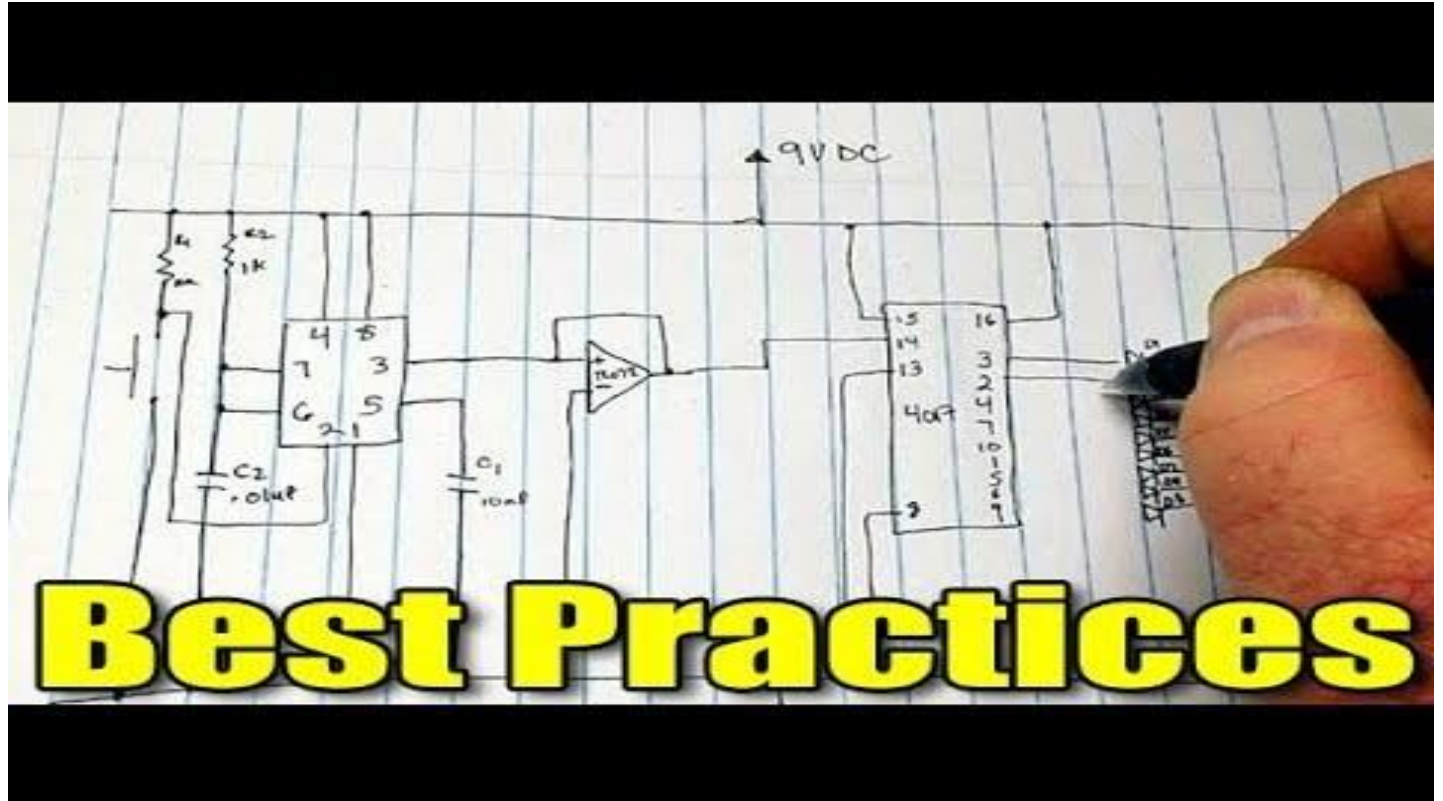

Best Practices

Click on the above video to learn how to draw schematic diagrams for electronics.



Know Your Prefixes

- Many electronic units must be multiplied or divided by powers of 10 to be easily used.
 - Examples are Kilobytes and Microfarads.
- These are the common multipliers used in electronics and their meanings:
 - **Tera** - 1 Trillion 1,000,000,000,000 or 1×10^{12}
 - **Giga** - 1 Billion 1,000,000,000 or 1×10^9
 - **Mega** - 1 Million 1,000,000 or 1×10^6
 - **Kilo** - 1 Thousand 1,000 or 1×10^3
 - **Milli** - One Thousandth $1 / 1,000$ or 0.001 or 1×10^{-3}
 - **Micro** - One Millionth $1 / 1,000,000$ or 0.000001 or 1×10^{-6}
 - **Nano** - One Billionth or 1×10^{-9}
 - **Pico** - One trillionth or 1×10^{-12}

Electronic Symbols

- Download the document “**Circuit Symbols in Diagrams**” that accompanies this presentation for a list of circuit symbols along with their meanings and uses.

Wire and connection symbols

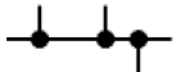
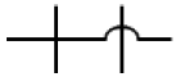
	Wire	Connects components and passes current easily from one part of a circuit to another.
	Wires joined	A 'blob' should be drawn where wires are connected (joined), but it is sometimes omitted. Wires connected at 'crossroads' should be staggered slightly to form two T-junctions, as shown on the right.
	Wires not joined	In complex diagrams it is often necessary to draw wires crossing even though they are not connected. The simple crossing on the left is correct but may be misread as a join where the 'blob' has been forgotten. The bridge symbol on the right leaves no doubt!

Schematic Diagrams of LED and Incandescent Flashlights

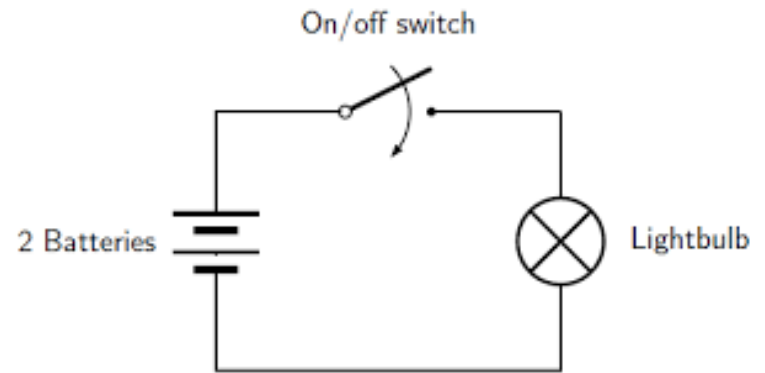
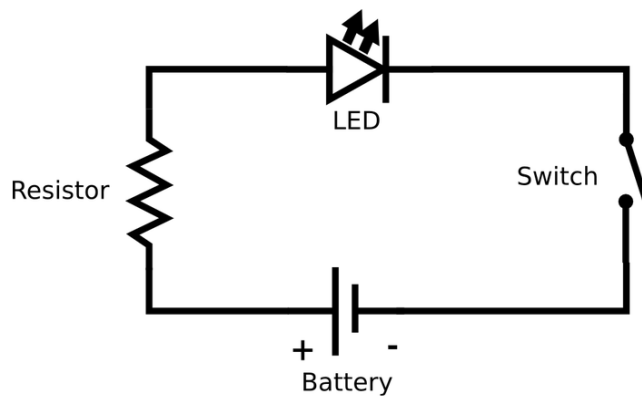

Schematic Diagrams

Draw a circuit to use the switch to turn ON and OFF the lamp AND the buzzer.

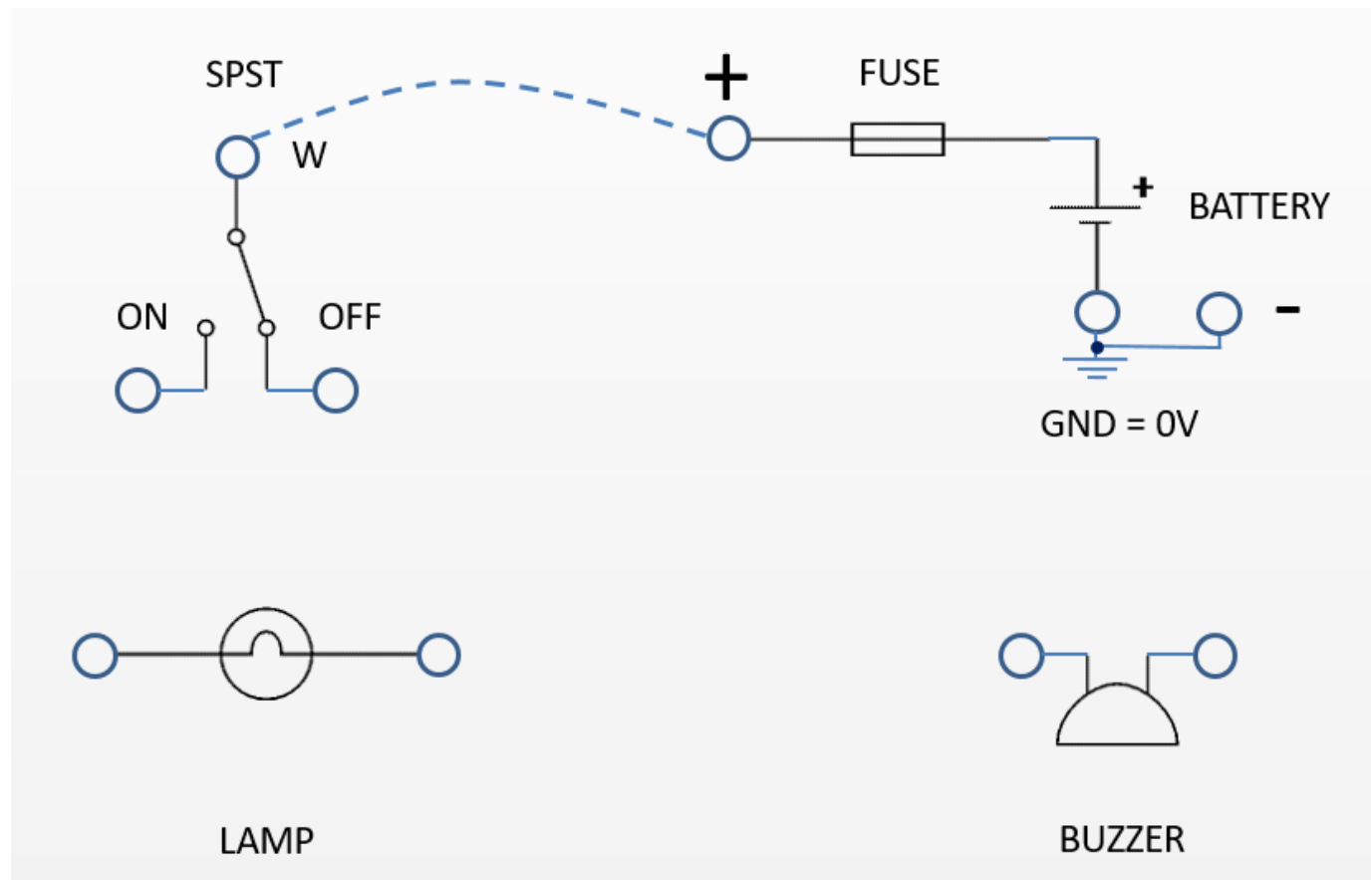

Schematic Diagrams

Circuit to use the switch to turn ON and OFF the lamp AND the buzzer solution.

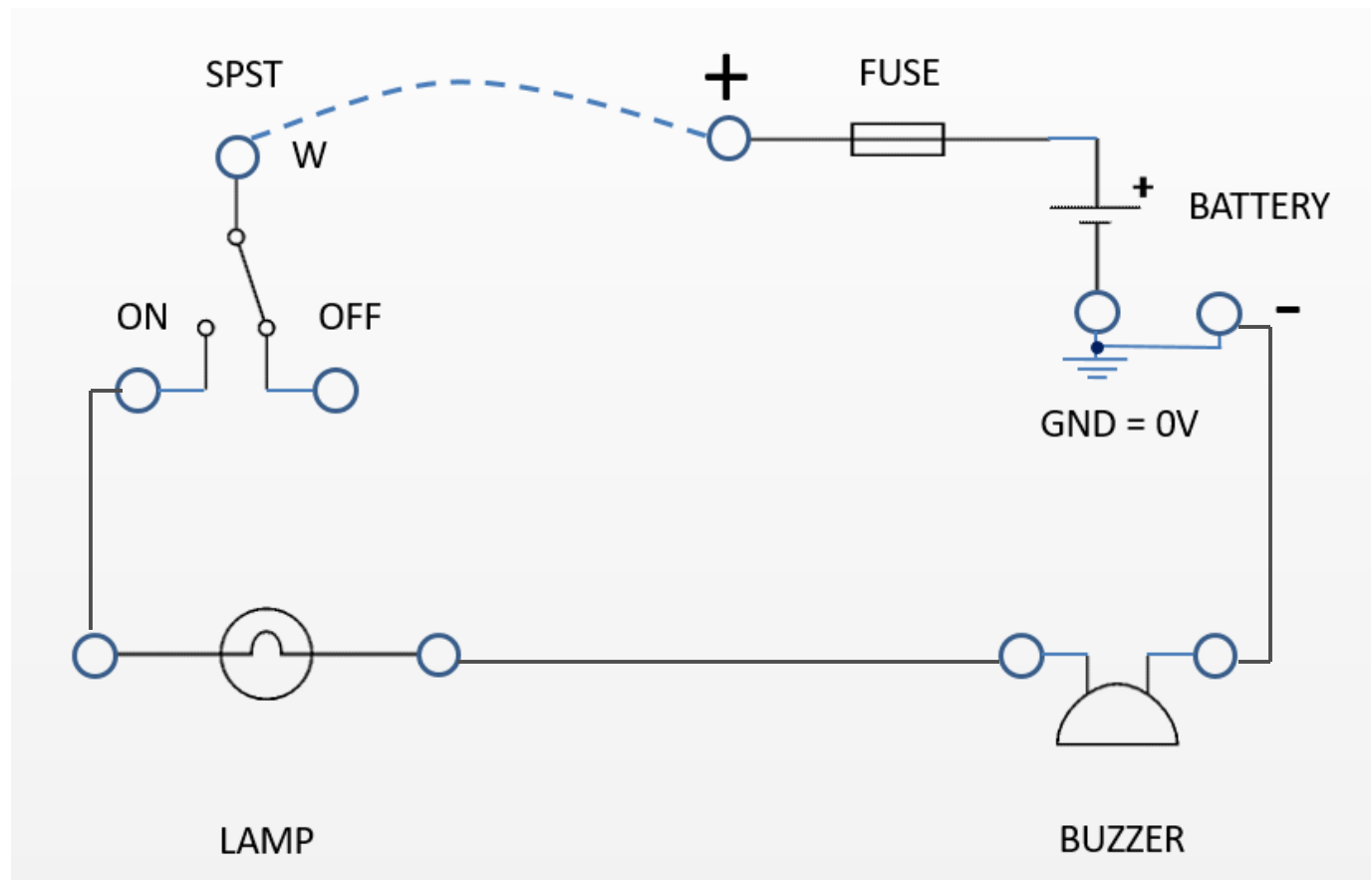

Schematic Diagrams

Draw a circuit to use the switch to turn ON the lamp OR the buzzer.

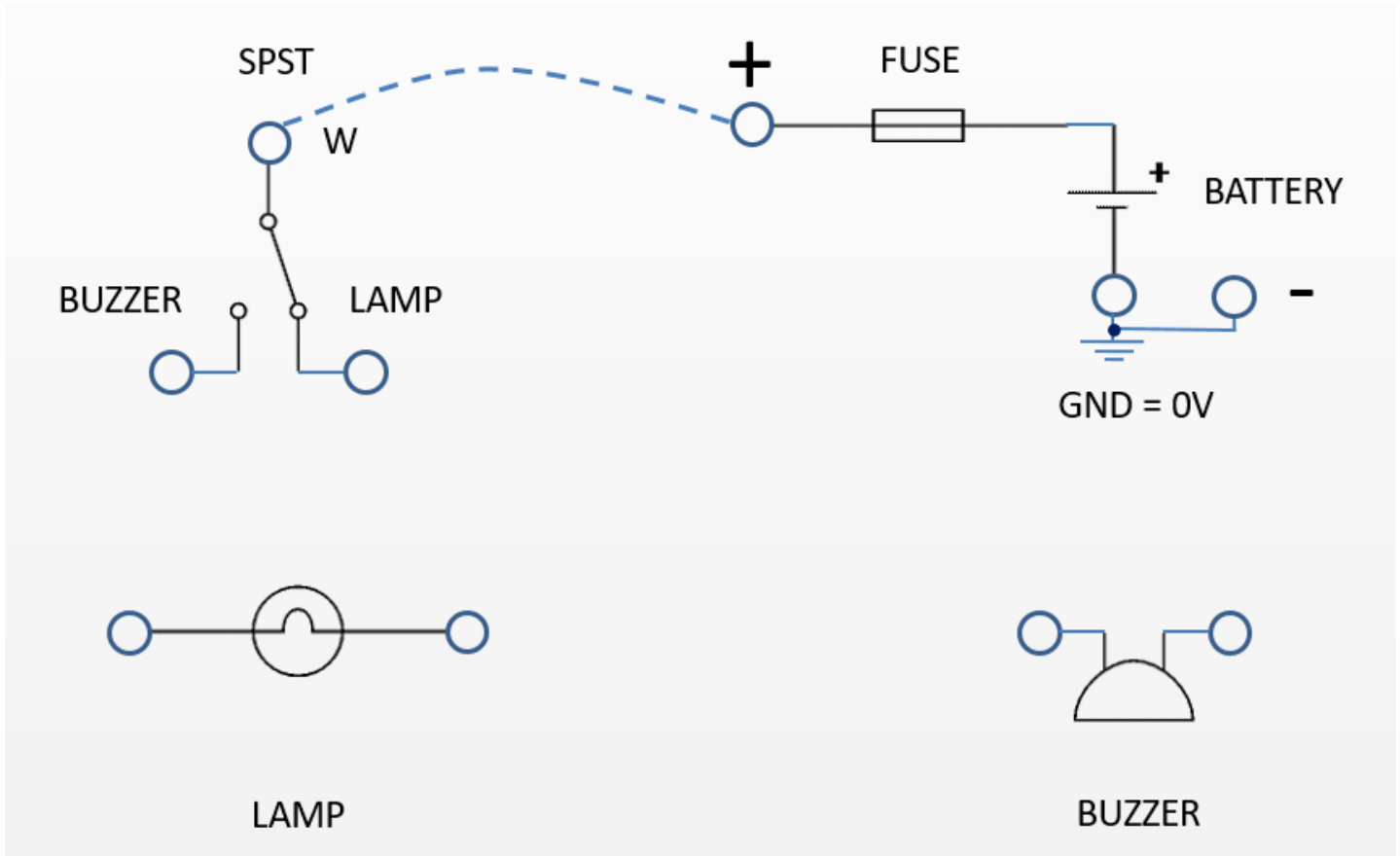

Schematic Diagrams

Circuit to use the switch to turn ON the lamp OR the buzzer solution.

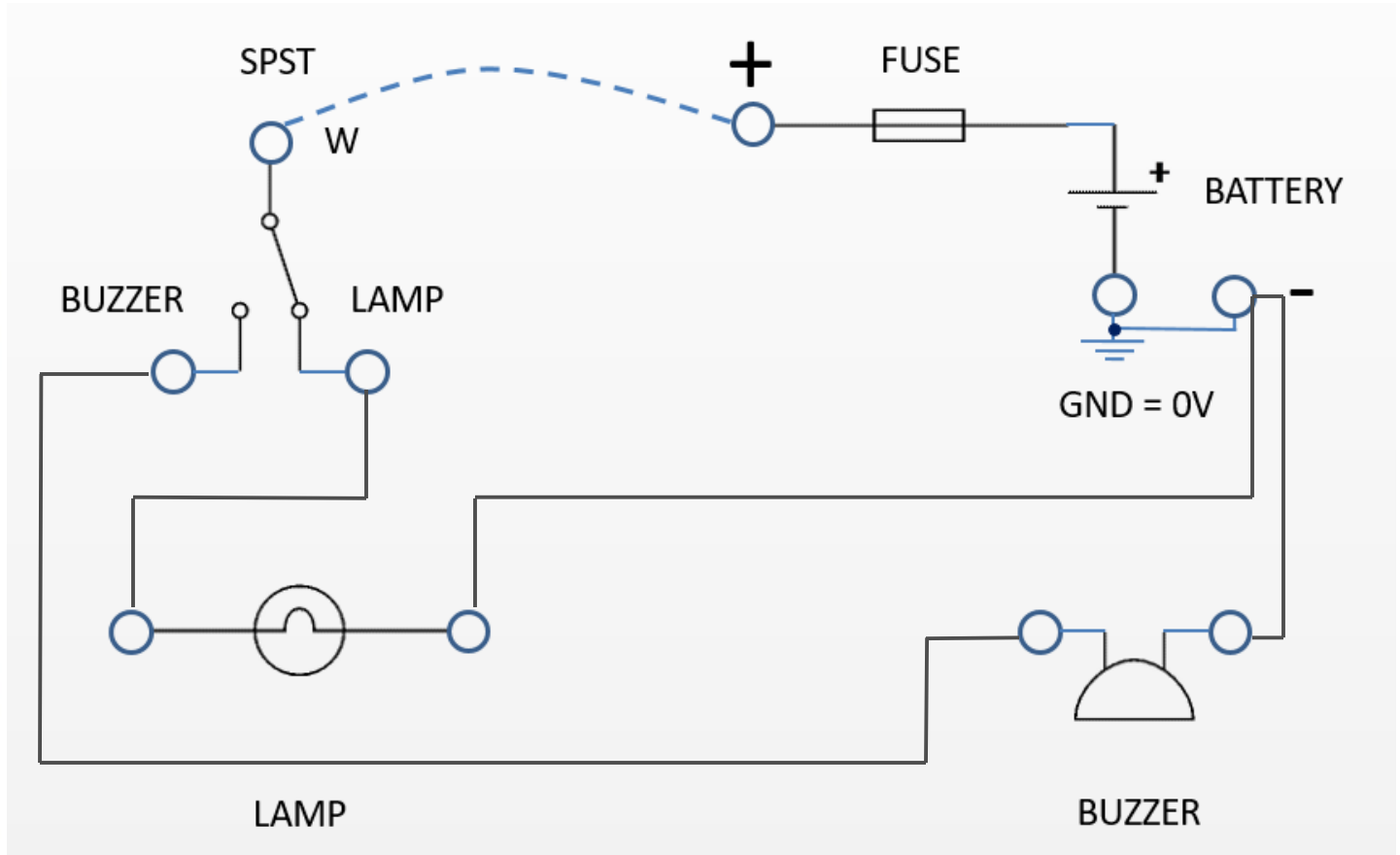

Pictorial vs. Schematic Diagram

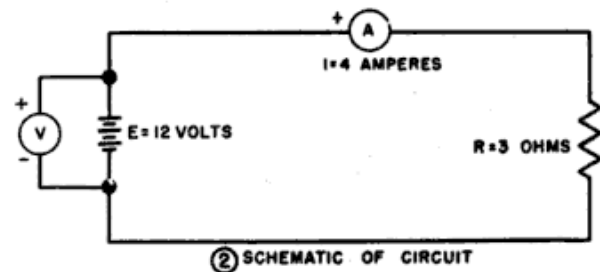
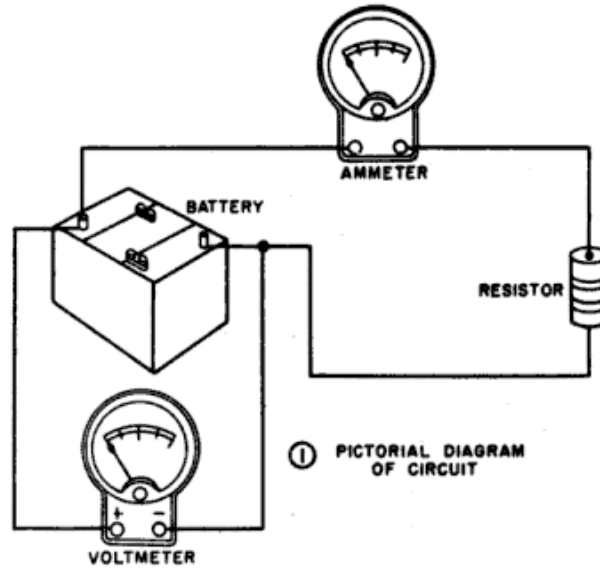
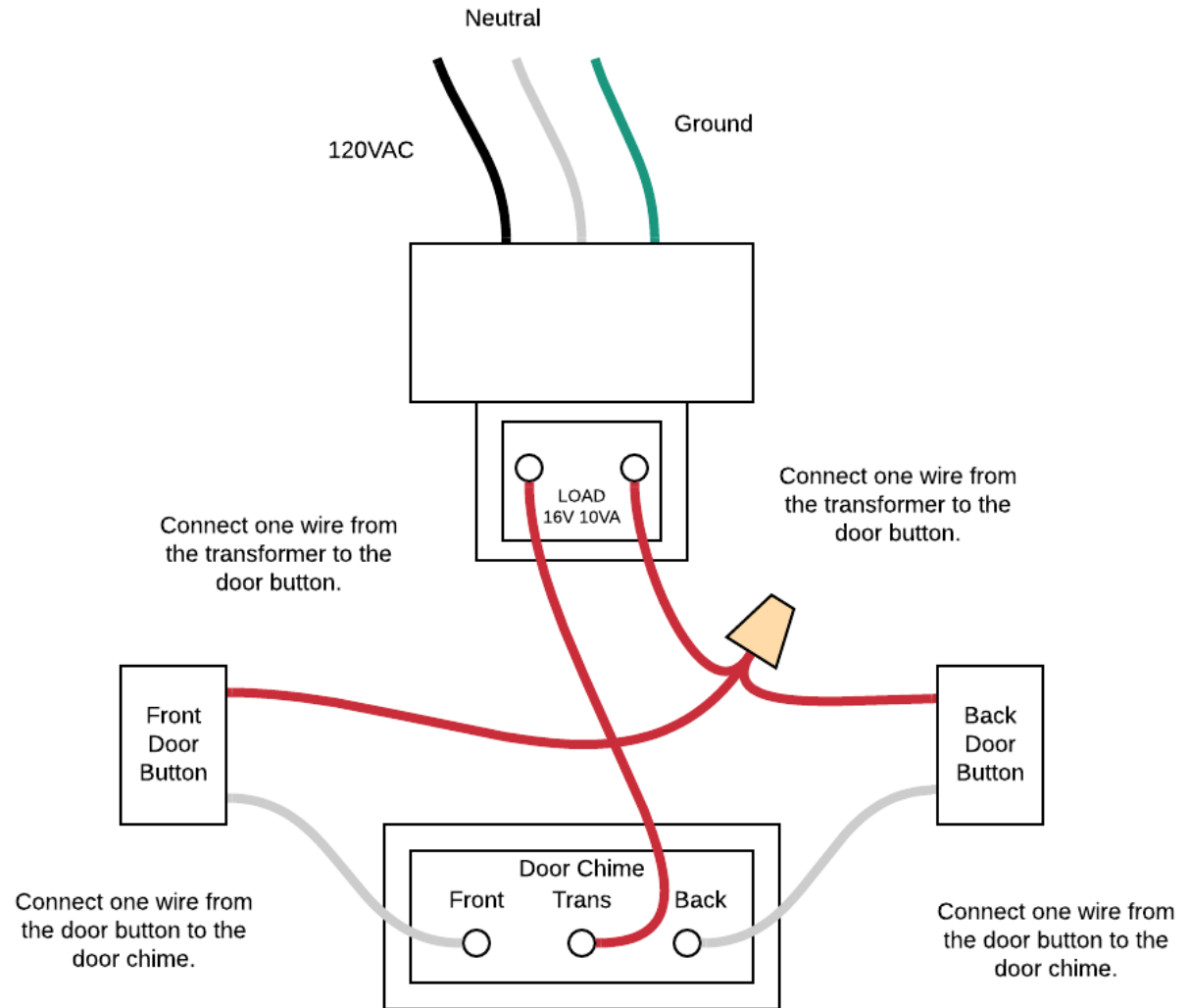

Figure 48. Diagram of a basic circuit.

- A pictorial circuit diagram uses simple images of components, while a schematic diagram shows the components and interconnections of the circuit using standardized symbolic representations.

Pictorial Diagram Door Chime



Schematic Diagram Door Chime

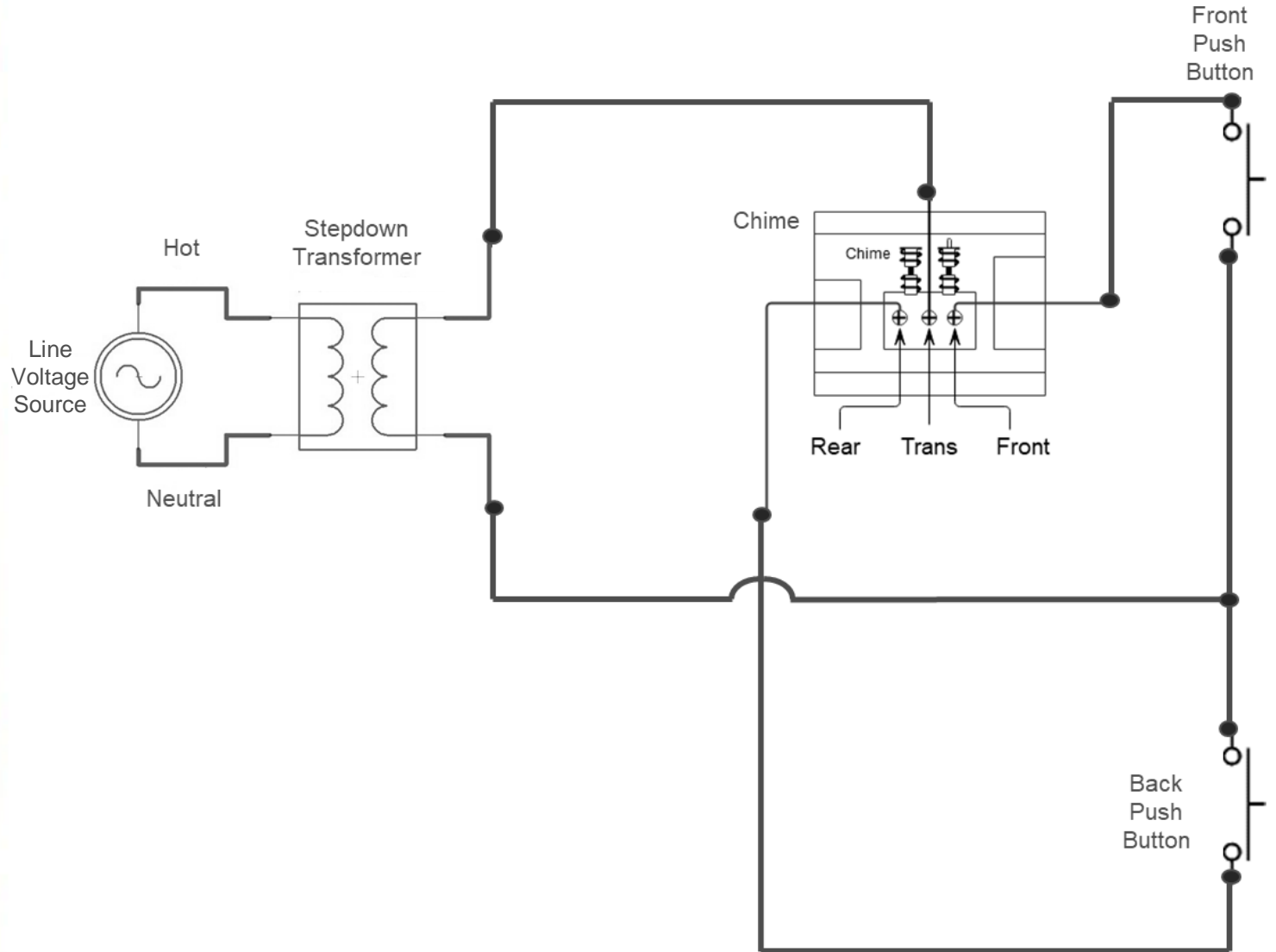

Requirement 3



Do the following:

- a. **Show the right way to solder and desolder.**
- b. Show how to avoid heat damage to electronic components.
- c. Tell about the function of a printed circuit board. Tell what precautions should be observed when soldering printed circuit boards.

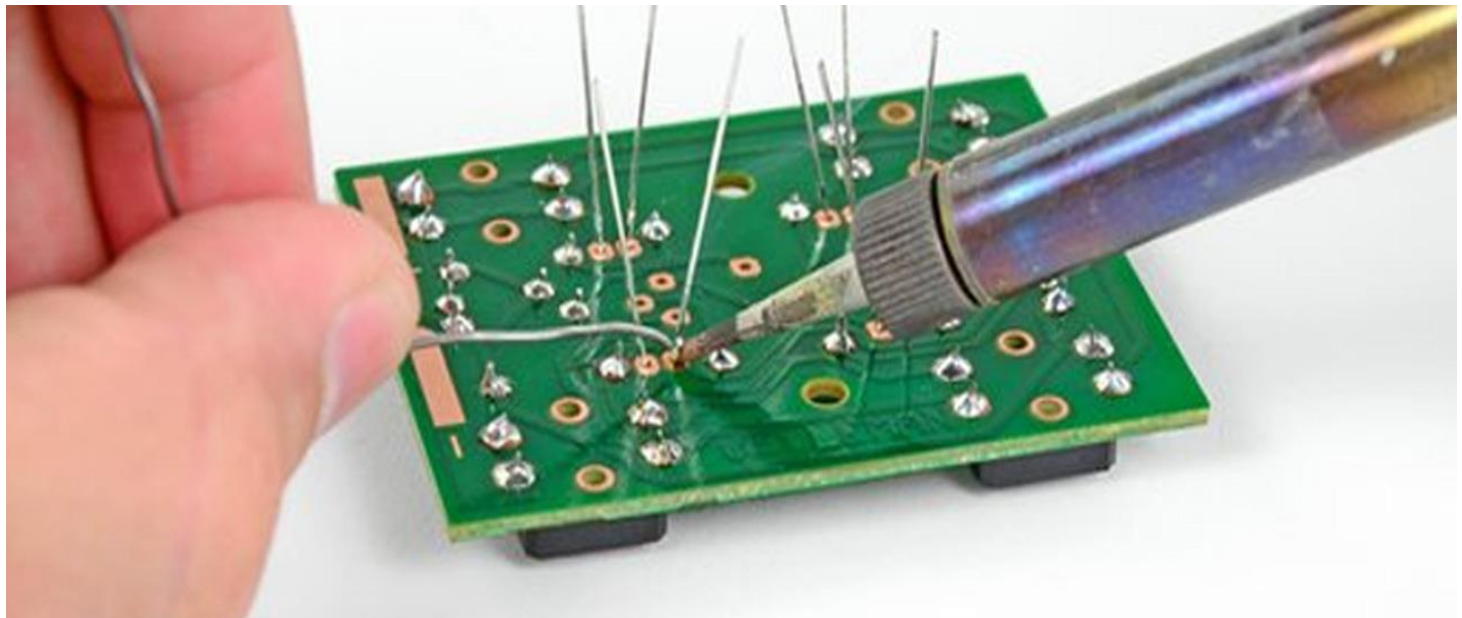

What is Soldering

- Soldering is a process of joining two metal surfaces together using a filler metal called solder.
- The soldering process involves heating the surfaces to be joined and melting the solder, which is then allowed to cool and solidify, creating a strong and durable joint.





Soldering Safety Tips

1. Solder only under the constant supervision of a responsible and knowledgeable adult.
2. Certain kinds of solder release fumes that can be harmful to your eyes and lungs. Always work with solder in a well-ventilated area.
3. Do not allow anyone to drink or eat in the soldering area.
4. Wear safety goggles when soldering.
5. Before you start soldering, protect any flammable material with a fireproof shield or wet rags, and have a fire extinguisher nearby.
6. Be careful not to let hot solder splash around because it will burn you almost instantly.



Soldering Safety Tips (cont.)

7. If possible, use a soldering iron stand or clamps when you are soldering, leaving one hand free to hold the solder.
8. Don't overheat components, circuit boards, or plastic wires when soldering.
9. Oxidation (rust) develops more rapidly when a soldering iron is hot, so try to make sure the iron doesn't stay hot for long periods of time.
10. Never touch the tip of a hot soldering iron; keep the iron in a holder when you aren't using it. Don't lay it down on your bench or work area.
11. Never leave a soldering iron on unattended.
12. When you are finished soldering and cleaning up, thoroughly wash your hands.

The Soldering Iron



- A soldering iron is composed of a heated metal tip (the bit) and an insulated handle.
- Heating is often achieved electrically through a resistive heating element.
- Soldering irons are designed to reach a temperature range of 200 to 480 °C (392 to 896 °F).
 - Solder melts at approximately 185 °C (365 °F).

Maintaining a Soldering Iron



Click on the above video to learn how to maintain a soldering iron.

How to Solder



Click on the above video to learn how to correctly solder electronics.

Desolder

- In electronics, desoldering is the removal of solder and components from a circuit board for troubleshooting, repair, replacement, and salvage.



Click on the above video to learn how to correctly desolder electronics.

Requirement 3



Do the following:

- a. Show the right way to solder and desolder.
- b. Show how to avoid heat damage to electronic components.**
- c. Tell about the function of a printed circuit board. Tell what precautions should be observed when soldering printed circuit boards.

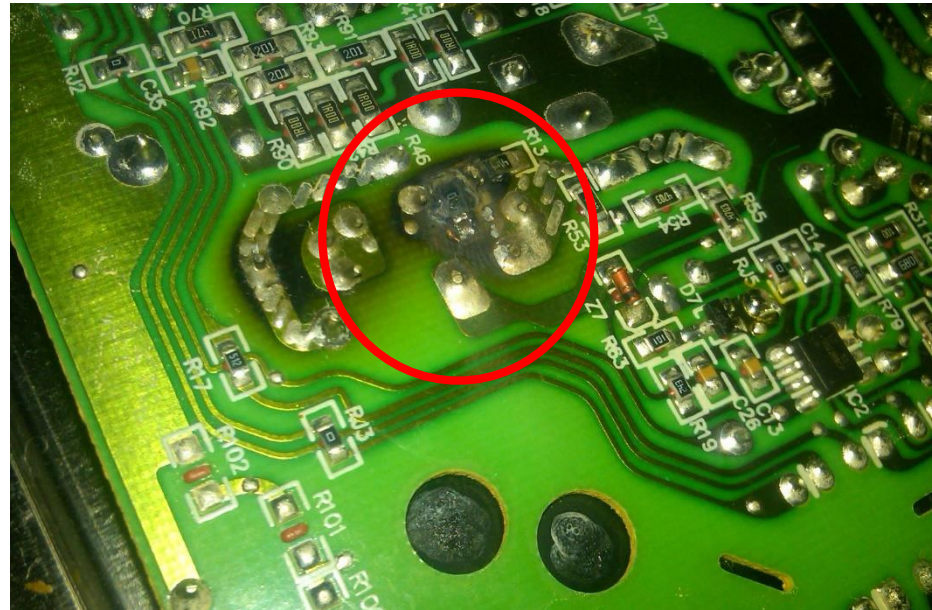



Avoiding Heat Damage

- Electronic components are designed to be soldered, so if you do it properly there is very little risk of heat damage.
- That usually means using a temperature controlled iron.
 - Select a soldering temperature that is hot enough to efficiently melt the solder, but not too hot.
 - Make sure that everything is perfectly clean.
 - Hold the soldering tip to the lead and contact point/pad until both are brought up to temperature.
 - Apply enough solder to cover the contact pad and surround the lead.
- Work quickly; you should be able to solder the joint in about 1 second.
- Under these conditions the risk of overheating is minimal.

Requirement 3



Do the following:

- a. Show the right way to solder and desolder.
- b. Show how to avoid heat damage to electronic components.
- c. Tell about the function of a printed circuit board. Tell what precautions should be observed when soldering printed circuit boards.

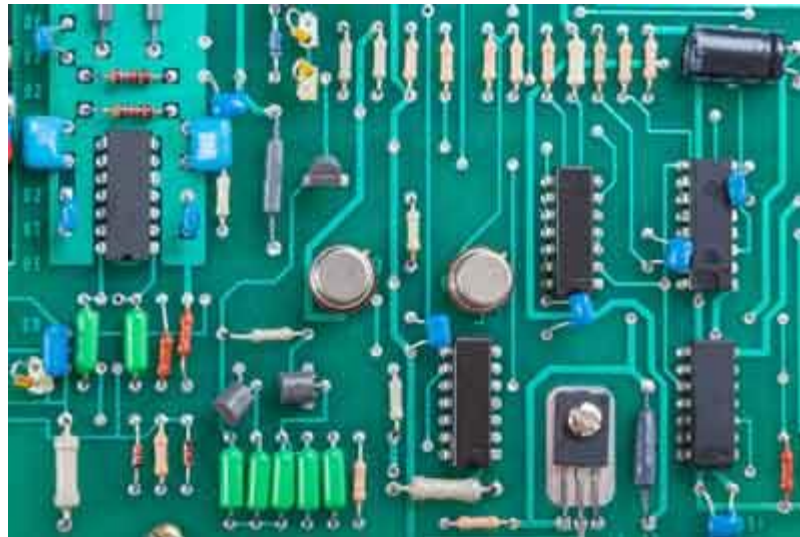

Purpose of Printed Circuit Boards

- Printed Circuit Boards (PCBs) are mainly used to provide mechanical support and create electronic pathways for the electrical components of a circuit.
- A PCB is made of a nonconducting material, such as a thin sheet of fiberglass or phenolic resin (plastic) that has a pattern of foil conductors “printed” on it and has predrilled holes designed to hold components.
- You insert component leads into the holes and solder the leads to the foil pattern.
- Printed circuit boards make assembly easier and are widely used.

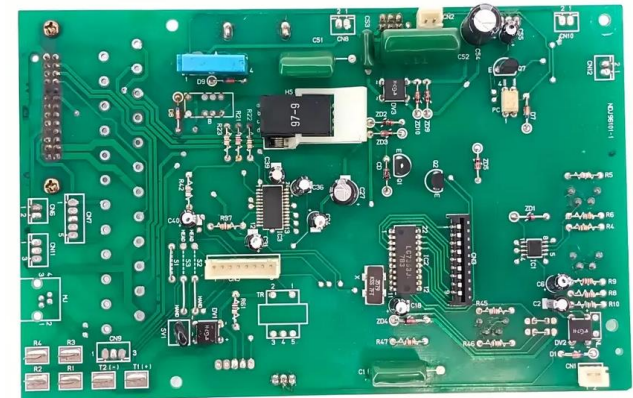
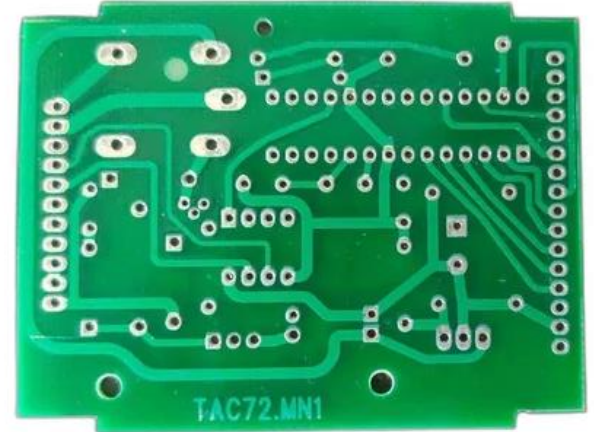

Soldering Circuit Boards

1. Prepare the Printed Circuit Board (PCB)

- a. Whether you're soldering a PCB or other surface, it's best to start with a clean surface. Clean your surface with an industrial cleaning wipe or acetone cleaner to remove any dust or other debris that may affect your soldering. Compressed air also helps remove small particles and dries the surface quickly.

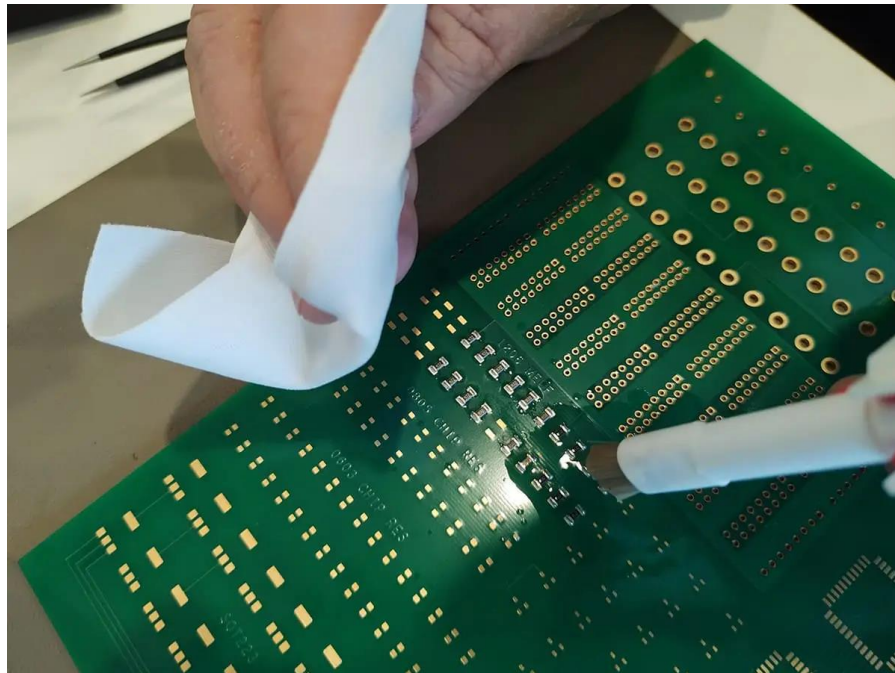

Soldering Circuit Boards

2. Position Your Components

- a. It's best to begin with the smaller components and finish with the larger components to prevent the surface from sitting unevenly and being weighed down by a heavy piece.
- b. Select the small components you'll start with and position them in their places on the surface. Insert components into appropriate holes on a PCB.
- c. If the components don't stay in place on a PCB, you can bend the leads slightly under the board so they hold still.

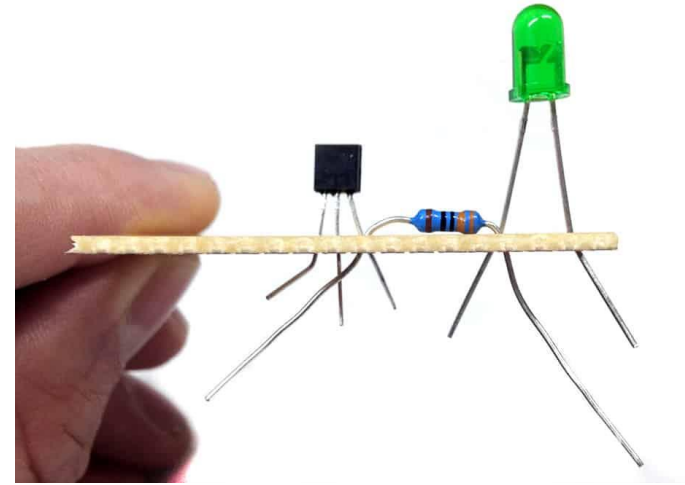

Soldering Circuit Boards

3. Heat the Joint

- a. Heating the joint conducts the iron's heat to the PCB to prepare the board for soldering.
- b. With a small amount of solder on the iron's tip, touch the tip to the component lead and board.
- c. Connecting the tip with both these pieces is critical to ensure the solder sticks them together and heats them properly.
- d. Only hold the iron on the joint for a few seconds, as overheating the joint will cause bubbling.
- e. Use caution during this step to prevent overheating.

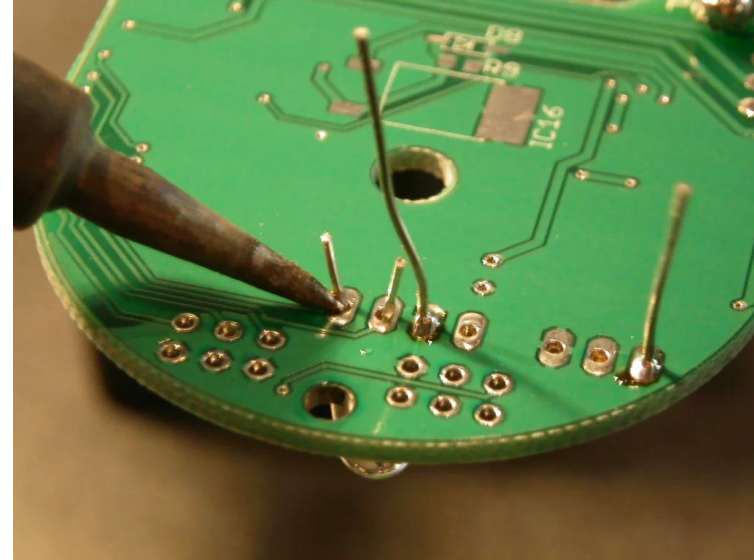

Soldering Circuit Boards

4. Solder the Joint

- a. Now your joint is ready to solder. While you'll want to keep your iron near the joint, you shouldn't touch the solder strand to the iron. Instead, the solder should be applied directly to the heated joint.
- b. If it's been heated thoroughly and correctly, the hot joint will be enough to melt the solder and begin to flow freely. Continue touching the solder strand to the joint until a small mound has formed.
- c. Set the solder strand and iron aside, and allow the joint to cool. While it cools, it's essential to keep the surface flat and still, as moving it will result in a grainy, dull finish.

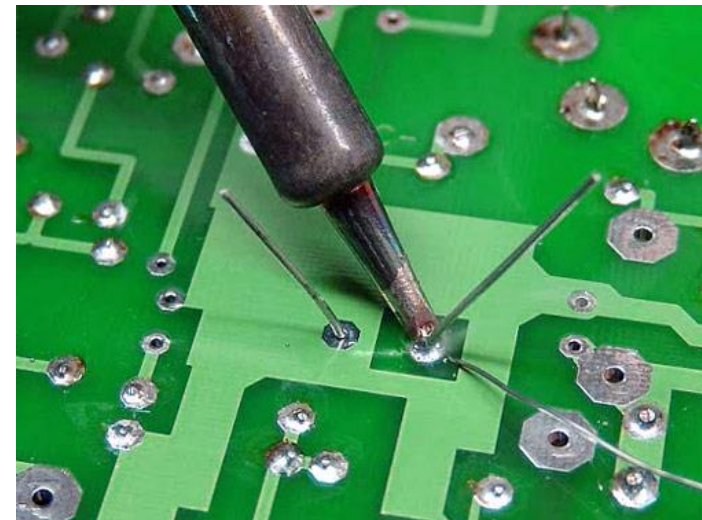
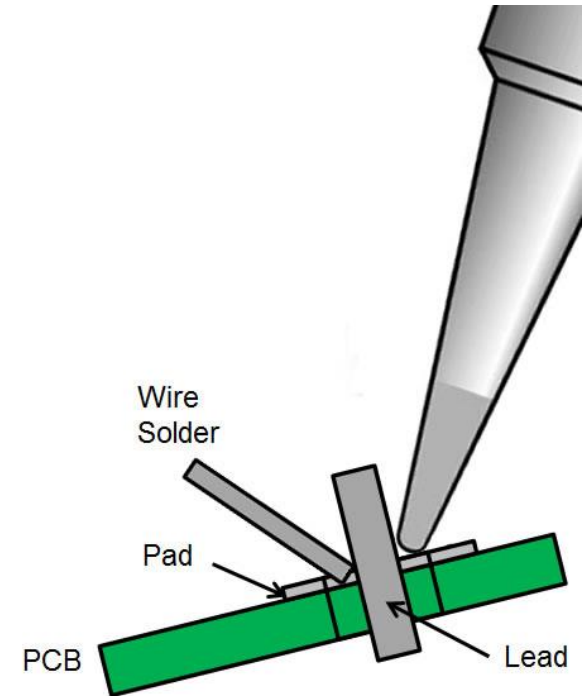

Soldering Circuit Boards

5. Inspect the Joint and Trim the Leads

- a. After the joint cools, visually inspect it to ensure it looks adequate.
- b. The finished solder joint should be a smooth, shiny cone.
- c. Once you're satisfied with the soldered joint, trim the lead and extra wire just above the joint.
- d. Solder the remaining components and clean any excess flux from the surface to finish the product.

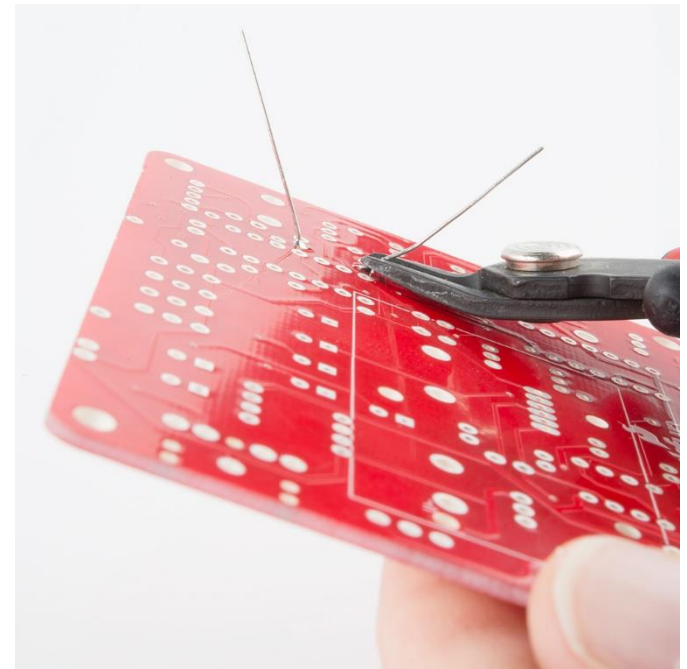
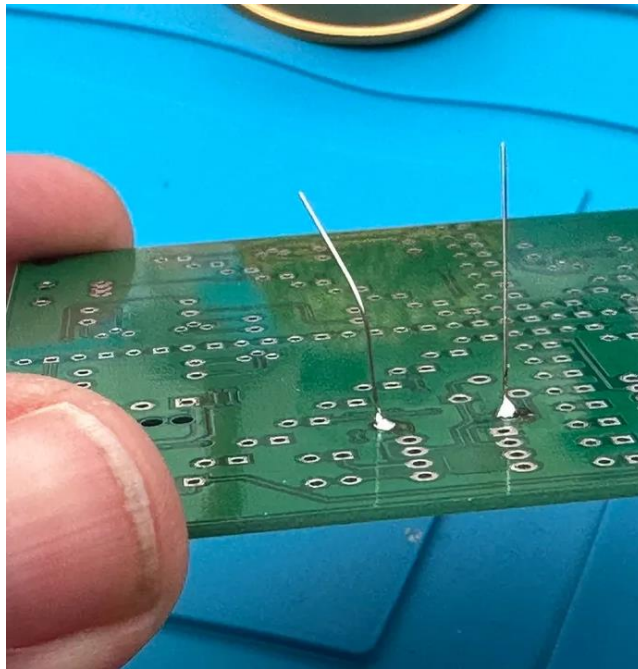

Soldering Circuit Boards

6. Solder Bridges

- a. Occasionally a solder “bridge” will form when solder connects between two adjacent foil conductors.
- b. You must remove such bridges or a short circuit will exist between the two conductors and the circuit won’t function properly.
- c. Place solder wick on top of the solder bridge and heat the wick using the soldering iron by pressing on top of the affected area.
- d. Continue to apply pressure with the soldering iron to the solder bridge until the solder is melted and absorbed by the wick.
- e. A soldering flux can also be used here to aid in desoldering.

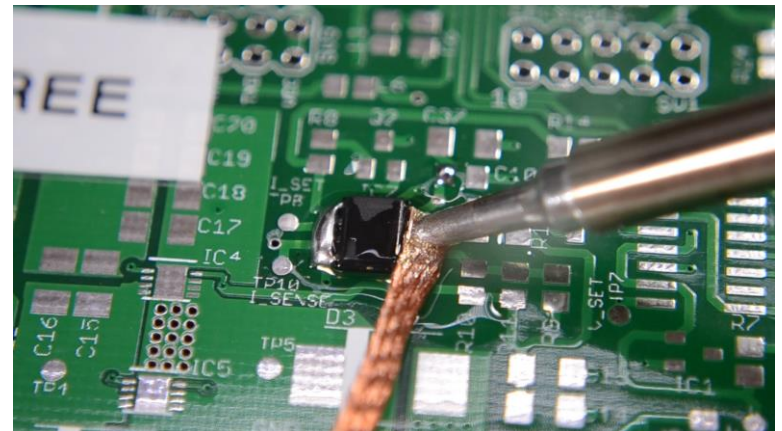
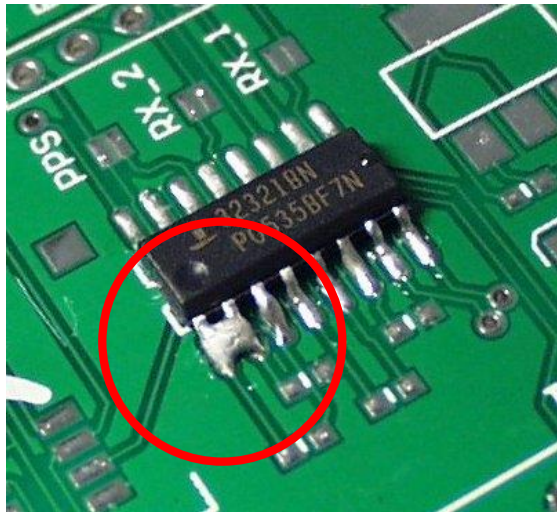

Requirement 4



4. Do the following:

- a. Discuss each of the following with your merit badge counselor:
 1. How to use electronics for a control purpose
 2. The basic principles of digital techniques
 3. How to use electronics for three different audio applications
- b. Show how to change three decimal numbers into binary numbers, and three binary numbers into decimal numbers.**
- c. Choose ONE of the following three projects. For your project, find or create a schematic diagram. To the best of your ability, explain to your counselor how the circuit you built operates.
 1. A control device
 2. A digital circuit
 3. An audio circuit

Decimal - Base 10

- In base 10, there are 10 unique digits (0-9).
- When writing large numbers (more than 1 digit), each column represents a value 10 times larger than the previous column.
- We say, how many 1's, how many 10's and how many 100's are there?

123

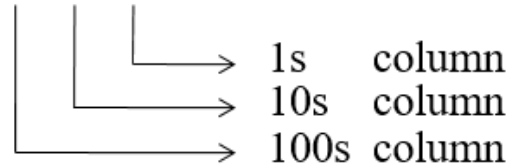

There is 1 '100' and
2 '10's and
3 '1's,

Making this number equal to
one hundred and twenty three.

Binary - Base 2

- In base 2 (binary) there are two numbers, 0 and 1.
- When writing large numbers (more than 1 digit), each column represents a value 2 times larger than the previous column.
- We say, how many 128s, how many 64s how many 32s, how many 16s, how many 8s, how many 4s, how many 2s and how many 1s are there?

1011

→	1s	column
→	2s	column
→	4s	column
→	8s	column

There is 1 '8' and
1 '2' and
2 '1',
making this number equal to eleven.

Counting to 16 in Binary

Decimal Number	16	8	4	2	1	Binary Number
0	0	0	0	0	0	0
1	0	0	0	0	1	1
2	0	0	0	1	0	10
3	0	0	0	1	1	11
4	0	0	1	0	0	100
5	0	0	1	0	1	101
6	0	0	1	1	0	110
7	0	0	1	1	1	111
8	0	1	0	0	0	1000
9	0	1	0	0	1	1001
10	0	1	0	1	0	1010
11	0	1	0	1	1	1011
12	0	1	1	0	0	1100
13	0	1	1	0	1	1101
14	0	1	1	1	0	1110
15	0	1	1	1	1	1111
16	1	0	0	0	0	10000

Changing Decimal to Binary

- By repeatedly dividing a number by 2, we can convert from decimal to binary. Remember that an even number divided by 2 will have a remainder of 0. An odd number divided by 2 will have a remainder of 1. One divided by 2 will equal 0 with a remainder of 1.
- Let's convert the decimal number 8 to binary. You start by dividing 8 by 2, and then keep dividing the answer you get by 2.

8 divided by 2 = 4 with a remainder of 0
4 divided by 2 = 2 with a remainder of 0
2 divided by 2 = 1 with a remainder of 0
1 divided by 2 = 0 with a remainder of 1

We arrange the remainders like this: 1 0 0 0

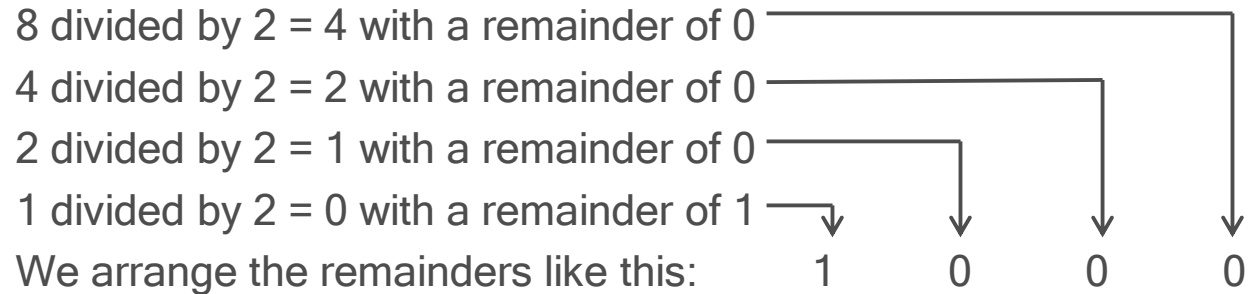

- Check the decimal/binary chart and you will see that 1000 is the binary equivalent of 8.
- Convert 13 to a binary number

13 divided by 2 = 6 with a remainder of 1
6 divided by 2 = 3 with a remainder of 0
3 divided by 2 = 1 with a remainder of 1
1 divided by 2 = 0 with a remainder of 1

Arrange the remainders: 1 1 0 1

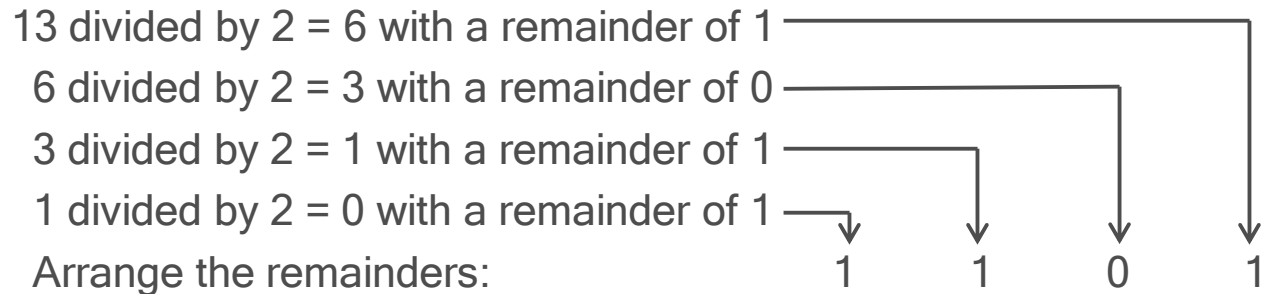

- Check the decimal/binary chart and you will see that 1101 is the binary equivalent of 13.

Changing Binary to Decimal

- Convert the binary number 1001 to its decimal equivalent. We will do the opposite of what we just did; that is, instead of dividing by 2, we will multiply by 2. First write the binary number with the digits spread apart, like this:

1 0 1 1

- Under the digit on the right, write the number 1. Multiply 1 by 2; the answer is 2. Write 2 under the next number. Multiply 2 by 2 (equals 4), and write 4 under the next number. Multiply 4 by 2 (equals 8), and write 8 under the next number:

1 0 1 1
8 4 2 1

- Now, add together the bottom numbers that appear under a 1. In the example, 8, 2, and 1 are written under 1s, so $8 + 2 + 1 = 11$. Check the decimal/binary chart and you will see that 11 is the decimal number for 1011.

- Convert the binary number 10110 to a decimal number:

1 0 1 1 0
16 8 4 2 1

- Adding the numbers under 1s, you get $16 + 4 + 2 = 22$

Decimal/Binary Problems

<u>Decimal</u>				<u>Binary</u>				
		8	4	2	1			
10	=	1	0	1	0	$8 + 2 = 10$		
6	=							
9	=							
15	=							
	=			1	1			
	=		1	0	1			
	=	1	1	0	1			

Decimal/Binary Problems

Solution

Decimal

Binary

		8	4	2	1	
10	=	1	0	1	0	$8 + 2 = 10$
6	=		1	1	0	
9	=	1	0	0	1	
15	=	1	1	1	1	
3	=			1	1	
5	=		1	0	1	
13	=	1	1	0	1	

Requirement 4



Do the following:

- a. Discuss each of the following with your merit badge counselor:
 1. How to use electronics for a control purpose
 2. The basic principles of digital techniques
 3. How to use electronics for three different audio applications
- b. Show how to change three decimal numbers into binary numbers, and three binary numbers into decimal numbers.
- c. Choose ONE of the following three projects. For your project, find or create a schematic diagram. To the best of your ability, explain to your counselor how the circuit you built operates.
 1. A control device
 2. A digital circuit
 3. An audio circuit

Electronics and Control Devices

- A control system is a system that is used to control the behavior of a device or process.
- It is made up of three main components: a sensor, a controller, and an actuator.
 - The sensor detects a physical quantity such as temperature, pressure, or position and converts it into an electrical signal.
 - The controller processes this signal and generates an output signal that is used to control the actuator.
 - The actuator is a device that translates the output signal from the controller into a physical action, such as opening or closing a door, turning lights on or off, or sounding an alarm.



The Principles of Digital Techniques



- Digital electronics are electric circuits that work on only two fixed values: "1" and "0".
 - They use a series of 1's and 0's to store and communicate information.
 - They can also perform math using just 1's and 0's. This is called Boolean Math.
- How do they get just 1's and 0's?
 - In digital electronic circuits transmitting these binary ones and zeros over an electrical wire is just a matter of “switching” an electrical voltage ON and OFF (five volts = 1, zero volts = 0).
 - With these two signals most anything can be stored and communicated including the picture on the screen you're looking at right now. But it takes a LOT of these signals running VERY fast!



Digital Logic Gates

What Is a Logic Gate?

- A logic gate is a device that acts as a building block for digital circuits. They perform basic logical functions that are fundamental to digital circuits. Most electronic devices we use today will have some form of logic gates in them.
- In a circuit, logic gates work based on a combination of digital signals coming from its inputs. Most logic gates have two inputs and one output, and they are based on Boolean algebra. At any given moment, every terminal is in one of the two binary conditions: true or false. False represents 0, and true represents 1.
- Depending on the type of logic gate being used and the combination of inputs, the binary output will differ. A logic gate can be thought of like a light switch, where in one position the output is off (0), and in another, it is on (1). Logic gates are commonly used in integrated circuits (IC).
- There are seven basic logic gates: AND, OR, XOR, NOT, NAND, NOR and XNOR.

Digital Logic Gates

The AND Gate

- The AND gate is named so because, if 0 is false and 1 is true, the gate acts in the same way as the logical "and" operator.
- The following illustration and table show the circuit symbol and logic combinations for an AND gate. (In the symbol, the input terminals are on the left, and the output terminal is on the right.) The output is "true" when both inputs are "true." Otherwise, the output is "false." In other words, the output is 1 only when both inputs are 1.



Input 1	Input 2	Output
0	0	0
0	1	0
1	0	0
1	1	1

Digital Logic Gates

The OR Gate

- The OR gate gets its name from behaving like the logical inclusive "or." The output is true if one or both of the inputs are true. If both inputs are false, then the output is false. In other words, for the output to be 1, at least one input must be 1.

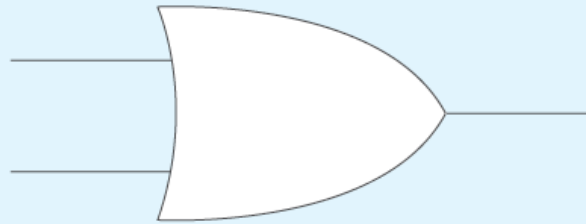

Input 1	Input 2	Output
0	0	0
0	1	1
1	0	1
1	1	1

Digital Logic Gates

The XOR Gate

- The XOR (exclusive-OR) gate acts in the same way as the logical "either/or." The output is true if either, but not both, of the inputs are true. The output is false if both inputs are "false" or if both inputs are true. Similarly, the output is 1 if the inputs are different but 0 if the inputs are the same.

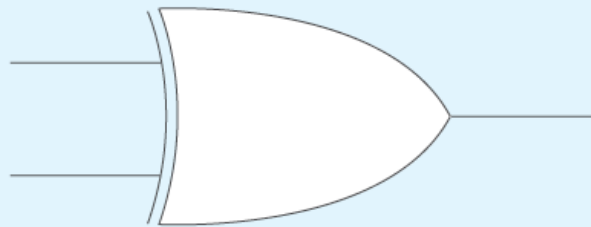

Input 1	Input 2	Output
0	0	0
0	1	1
1	0	1
1	1	0

Digital Logic Gates

The NOT Gate

- A logical inverter, sometimes called a NOT gate to differentiate it from other types of electronic inverter devices, has only one input. A NOT gate reverses the logic state. If the input is 1, then the output is 0. If the input is 0, then the output is 1.

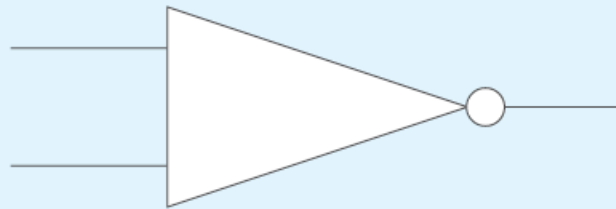

Input 1	Output
1	0
0	1

Digital Logic Gates

The NAND Gate

- The NAND (Negated AND) gate operates as an AND gate followed by a NOT gate. It acts in the manner of the logical operation "and" followed by negation. The output is false if both inputs are true. Otherwise, the output is true. Another way to visualize it is that a NAND gate inverts the output of an AND gate. The NAND gate symbol is an AND gate with the circle of a NOT gate at the output.

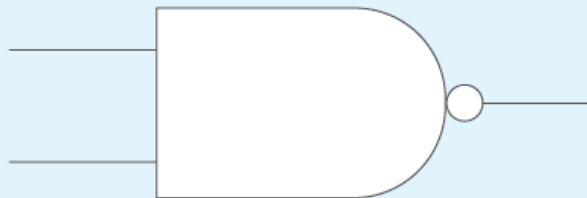

Input 1	Input 2	Output
0	0	1
0	1	1
1	0	1
1	1	0

Digital Logic Gates

The NOR Gate

- The NOR (NOT OR) gate is a combination OR gate followed by an inverter. Its output is true if both inputs are false. Otherwise, the output is false.

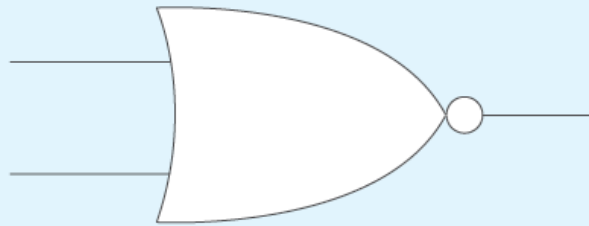

Input 1	Input 2	Output
0	0	1
0	1	0
1	0	0
1	1	0

Digital Logic Gates

The XNOR Gate

- The XNOR (exclusive-NOR) gate is a combination of an XOR gate followed by an inverter. Its output is true if the inputs are the same and false if the inputs are different.

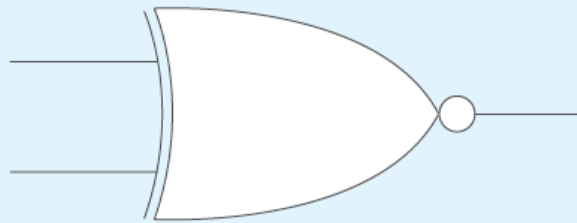

Input 1	Input 2	Output
0	0	1
0	1	0
1	0	0
1	1	1



Digital Logic Gates

Composition of Logic Gates

- On or off binary conditions are represented by different voltage levels. The logic state of a terminal can, and generally does, change as the circuit processes data. In most logic gates, the off (low) state is approximately zero volts (0 V), while the on (high) state is approximately five volts positive (+5 V).
- Logic gates can be made of resistors, transistors or diodes wired together in specific configurations to ensure they transform the inputs in expected ways.
 - Resistors are commonly used as a pull-up or pull-down resistor. Pull-up and pull-down resistors are used when there are any unused logic gate inputs to connect to a logic level 1 or 0. This prevents any false switching of the gate. Pull-up resistors are connected to V_{cc} (+5 V), and pull-down resistors are connected to ground (0 V).
 - Transistors provide switching -- turning on or off in response to input signals.
 - Diodes ensure current flows in only one direction to stabilize the circuit.

The Principles of Digital Techniques

What are electronic chips?

- Electronic chips are a whole bunch of electronic gates put into one small area. These chips can have millions and millions of gates in order to do all sorts of complex stuff. There are chips that do graphics for your computer screen, chips that have lots of memory for saving data, and chips that run programs like your computer's CPU. To make electronic chips, special materials called semiconductors are used together with expensive precision equipment. Hundreds of engineers may spend years just to design and invent one complex electronic chip.

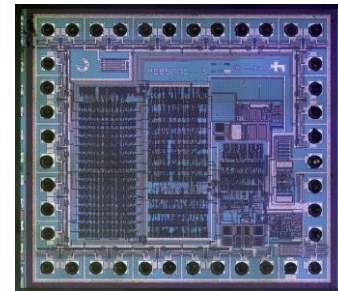
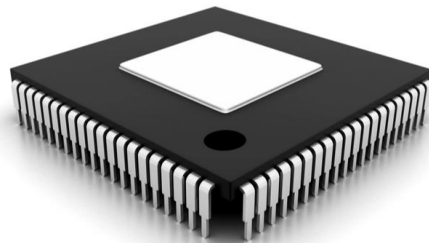

Integrated Circuit computer chip called a CPU

The Principles of Digital Techniques

Where Are Integrated Circuits Used?

- Integrated Circuits are used throughout the world including in computers, iPods, video games, televisions, cameras, cell phones, and cars.
- Although digital electronics are a relatively new invention in the world, most of us could hardly imagine a world without them.





Electronics and Audio Applications

- The field of audio deals with frequencies that are within the range of human hearing. A person with good ears can hear frequencies between 15 and 20,000 Hz. These extremes are considered the limits of the audio-frequency range. Audio equipment is used to produce, record, amplify, or reproduce frequencies in this range.
- Most audio equipment falls in one of these categories:
 - Hi-fi Stereo Field: CD and DVD players faithfully reproduce any sound within the audio range.
 - The Spoken Word: The human voice covers a narrow frequency range (about 100 to 3,000 Hz) so the frequency response of public address systems and intercoms do not need to cover the entire audio range.
 - Musical Instruments: Electronic keyboards, synthesizers, and electric guitars are examples. These instruments produce a wide range of frequencies and can create many special effects.

Microprocessor Controlled Counter Kit

- If you want to build a device from scratch, refer to the merit badge pamphlet for a parts list to purchase and step-by-step instructions.
- You may also click on the following link to purchase an upgraded version of the [Electronics Merit Badge Project Kit](http://www.electronicsemb.com) used at the National Scout Jamboree.

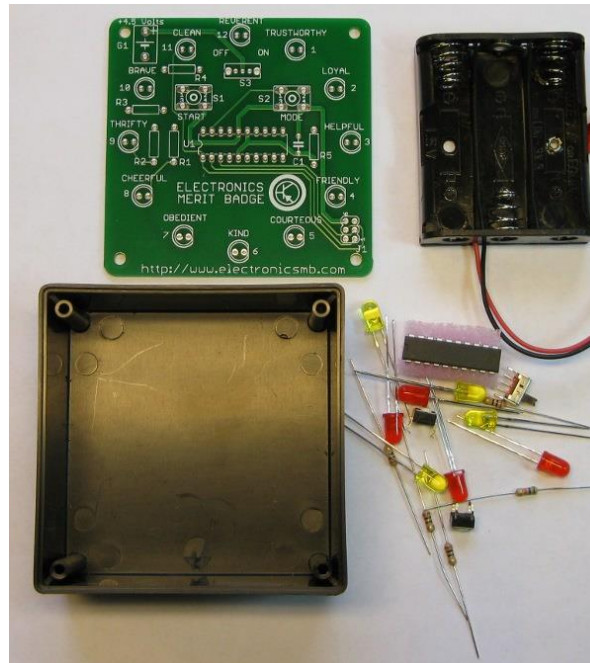

Unassembled Kit

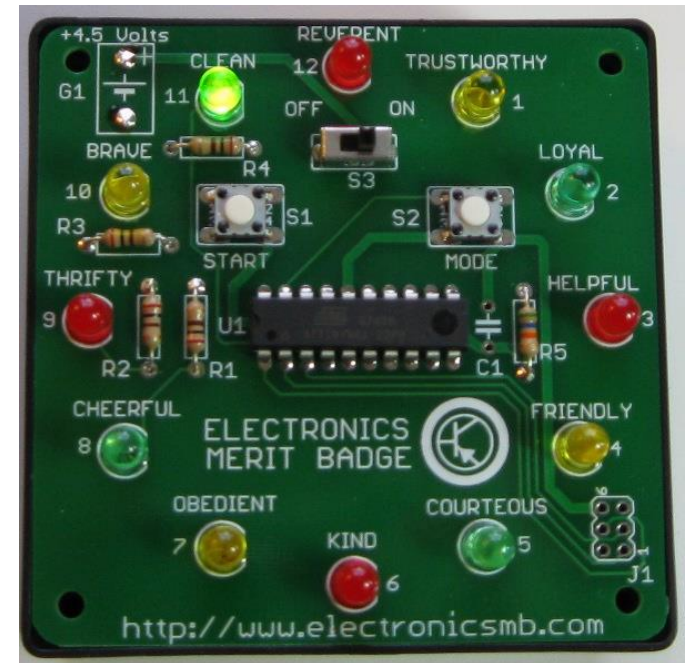

Assembled Kit

Microprocessor Controlled Counter Kit

The kit contains a microprocessor that will light 12 LEDs in a diminishing pattern.

The LEDs can be displayed in several different modes, though each mode starts as a fast pattern and slows to a stop.

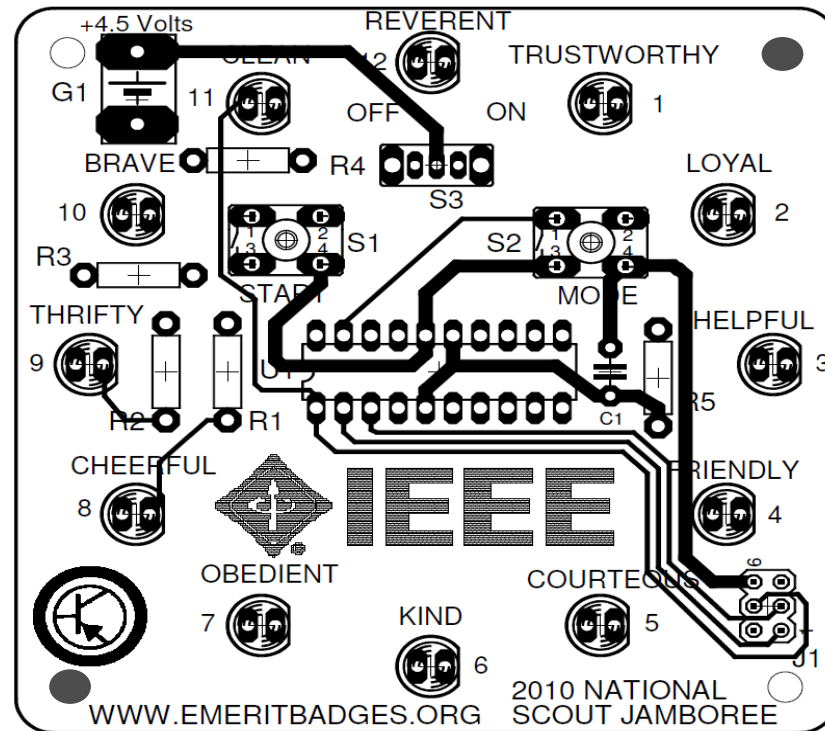

Microprocessor Controlled Counter Schematic

Draw the Schematic / Connect the lines

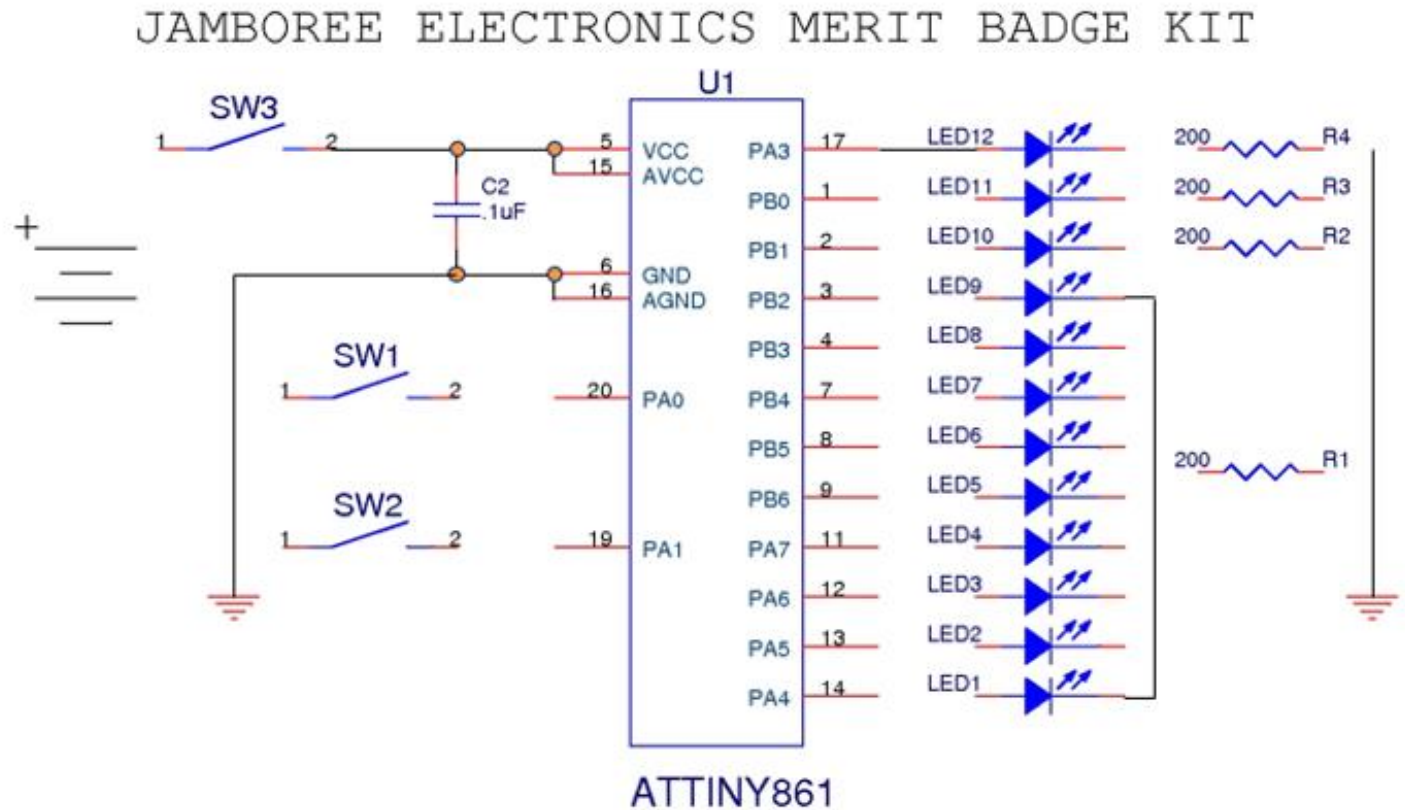

Microprocessor Controlled Counter Schematic

Draw the Schematic / Connect the lines

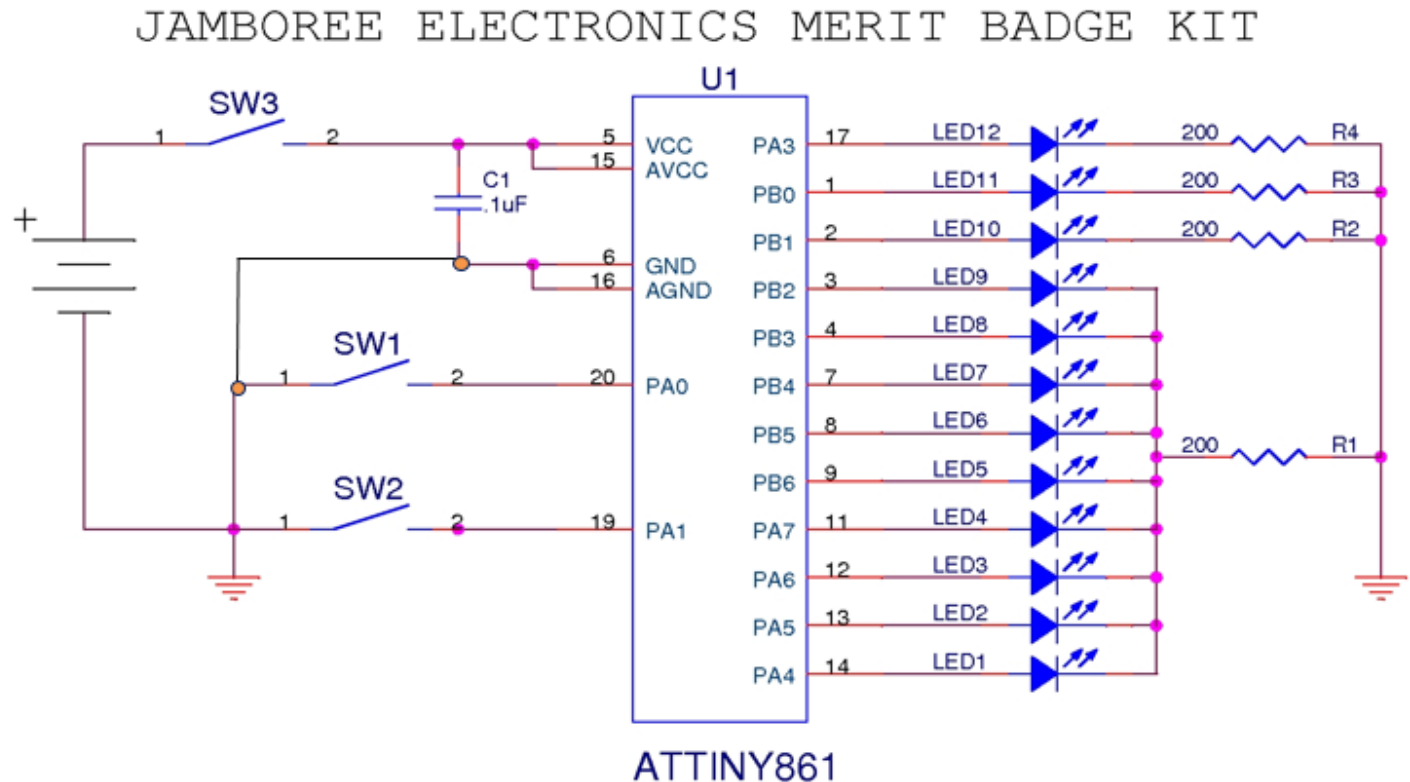

Microprocessor Controlled Counter Kit

1. Place components into PC board in the order recommended on instruction sheet
2. Bend leads out slightly to keep parts in place.
3. Follow instructions as to proper orientation of components.

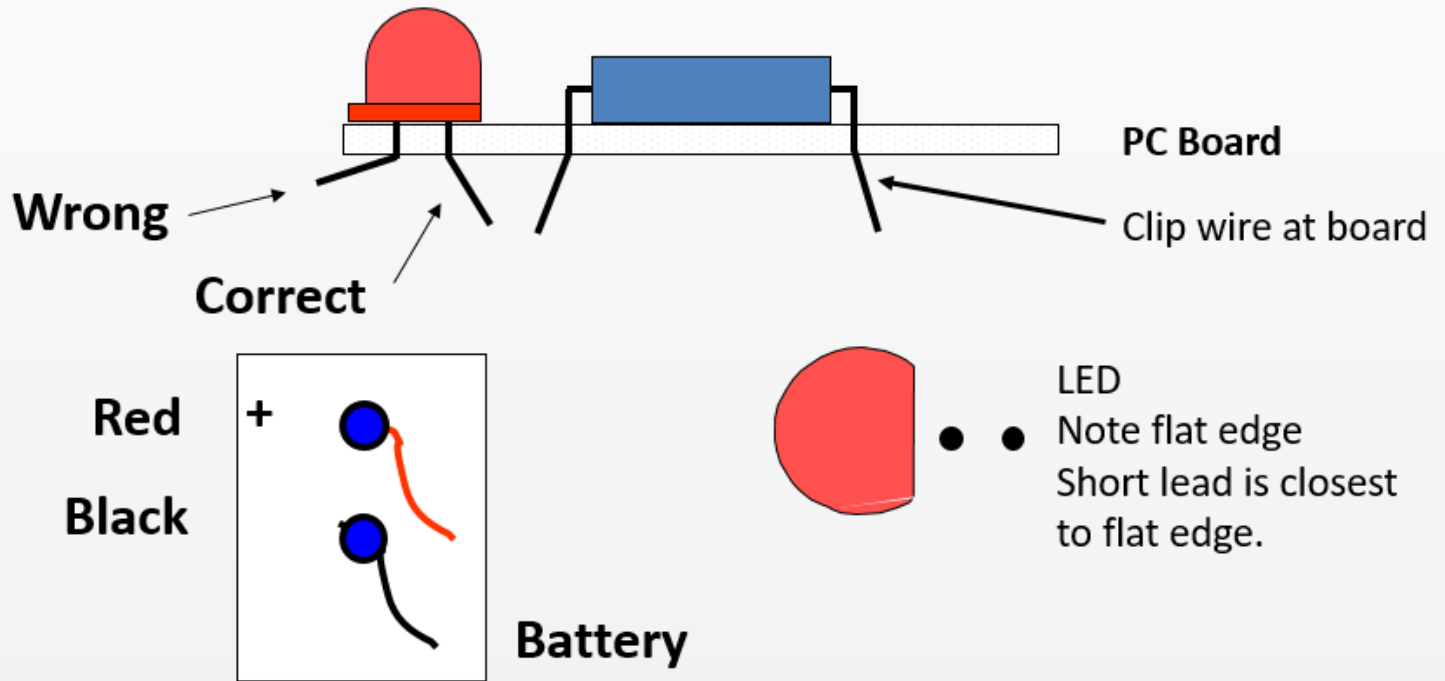

Microprocessor Controlled Counter Kit

The kit contains:

1. PC board
2. 1 Microprocessor – Atmel ATTINY861-20PU (U1)
3. 5 resistors R1-R4 = 200Ω, R5=56KΩ
4. 1 Capacitor C1 =.01uf
5. 12 LED's
6. 2 push buttons S1 & S2
7. 1 slide switch S3
8. 1 battery holder
9. 1 box with 2 screws

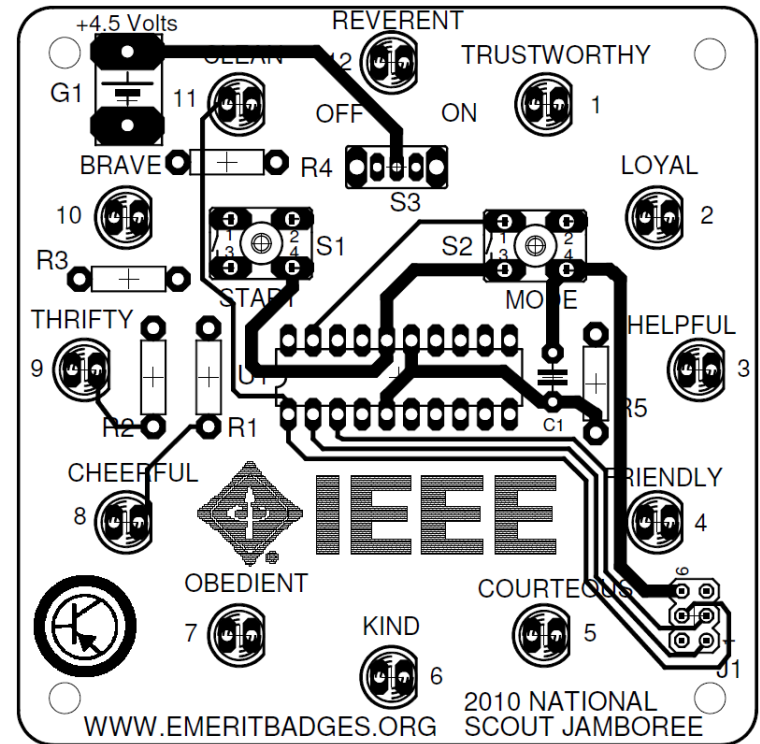



Microprocessor Controlled Counter Kit

Assembly Sequence

1. Place U1 on board. Note pin 1 orientation. Solder component into place.
2. Place resistors in board, bend leads out and solder, then cut leads.
3. Place all LEDs in board, bend leads out and solder, then cut leads.
4. Place capacitor in board, bend leads out and solder, then cut leads.
5. Place Switch S1, S2 & S3 in board and solder.
6. Place Red and Black battery wires from the back of the board and solder.
7. Place battery in box and cover with PC board
8. Use two screws to secure the PC board to box.

Microprocessor Controlled Counter Kit

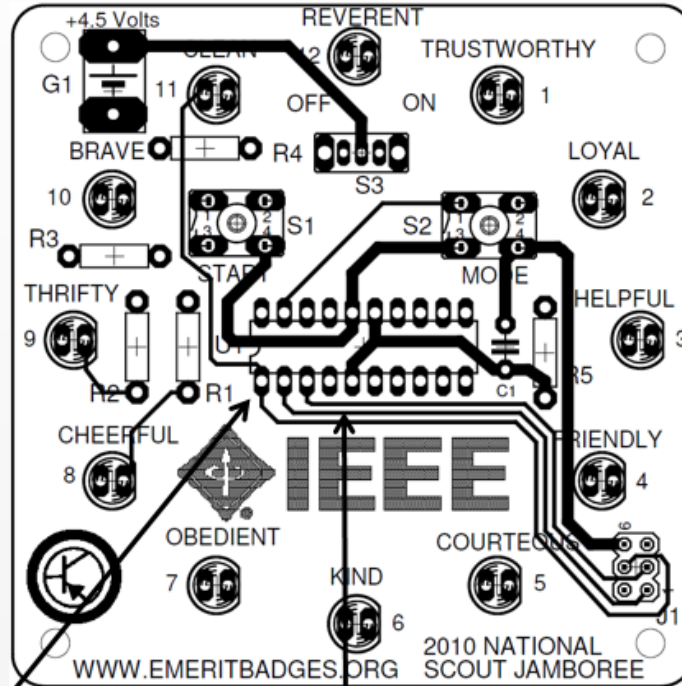

Pin 1

U1

Solder 20-pin DIP (Microprocessor) in U1 location. Orient U1 so that pin 1 is on the left.

Insert U1 into proper position on the board. Leads should come out the bottom of the board.

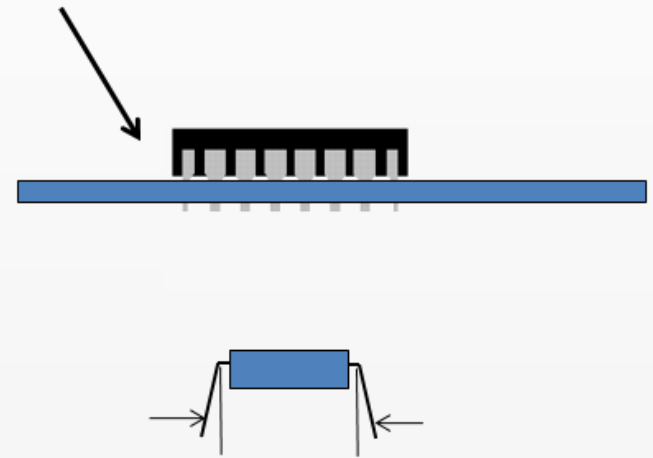

Note: You will need to bend all leads on each side to be more perpendicular to body of the component, before inserting the leads in the board.

Microprocessor Controlled Counter Kit

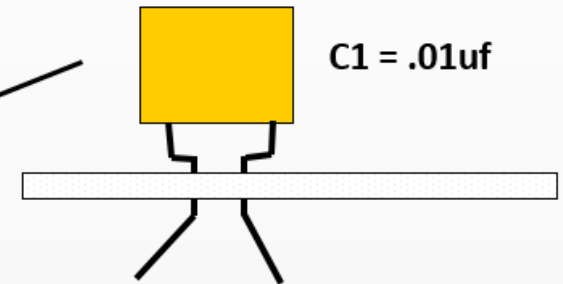
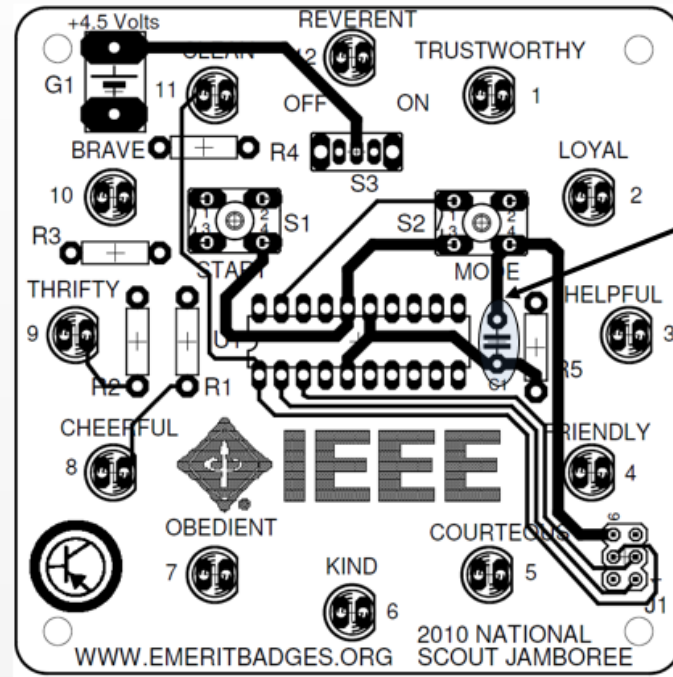

- Place capacitor at C1.
- Orientation of capacitor does not matter.
- Bend leads out.
- Solder leads.
- Carefully clip leads when done.

Microprocessor Controlled Counter Kit

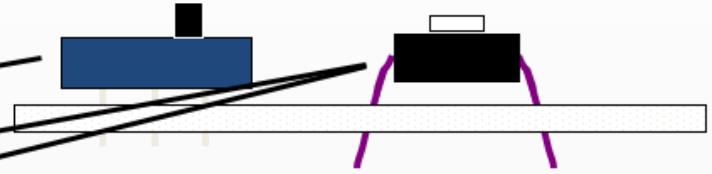
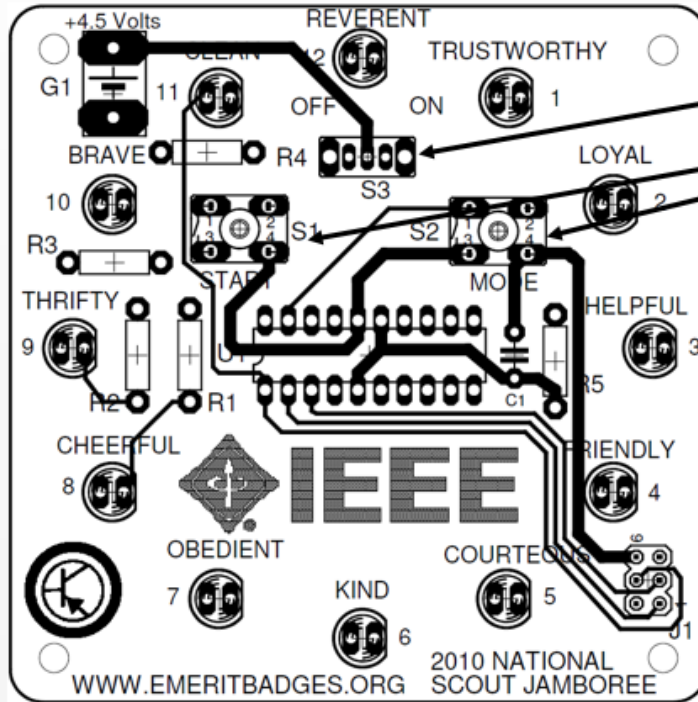

- Place Switches S1, S2 and S3 in their appropriate positions and solder.
- Make sure S3 (slide switch) is vertical, before soldering all the leads.

Microprocessor Controlled Counter Kit

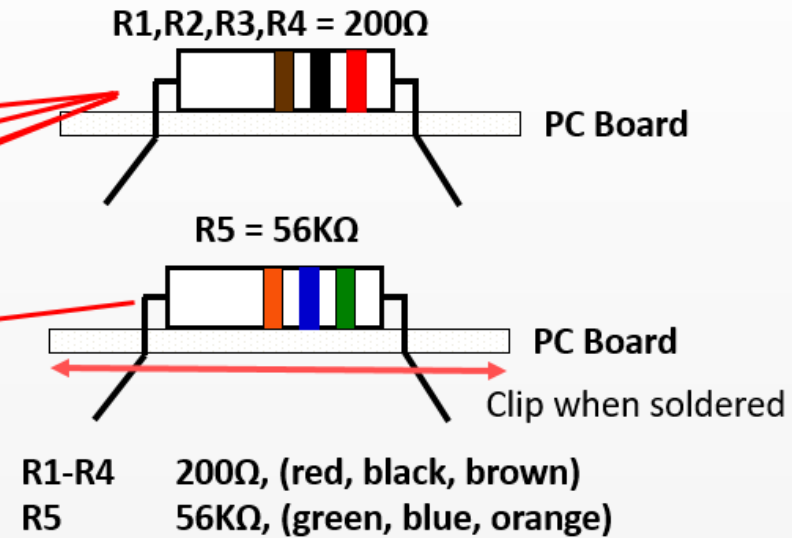
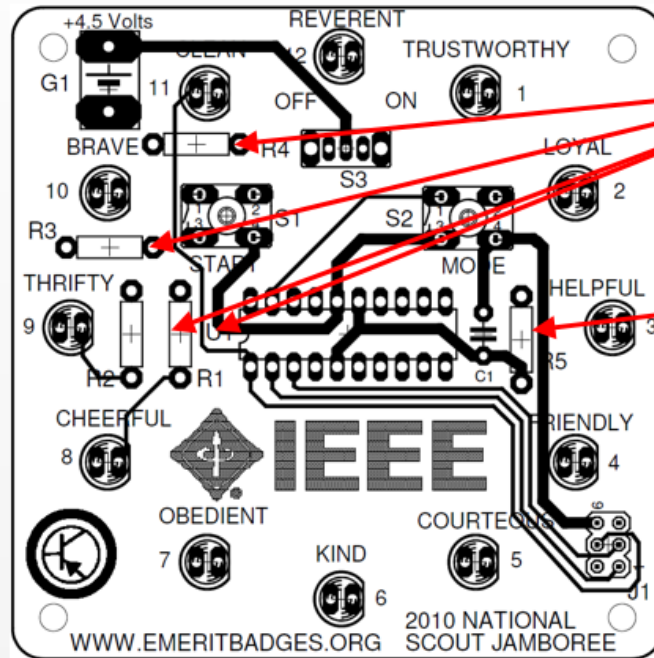

- Place resistors onto board.
- Direction of resistor does not matter.
- Check to be sure resistors are placed correctly.
- Bend leads out.
- Solder each lead.
- Carefully clip leads when done.

Microprocessor Controlled Counter Kit

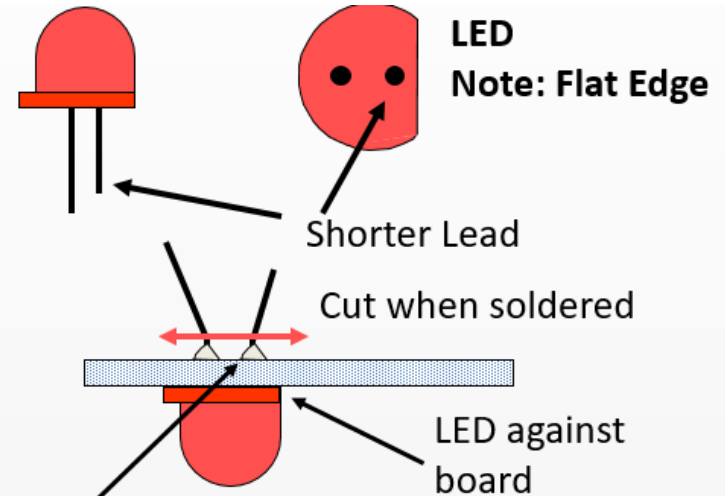
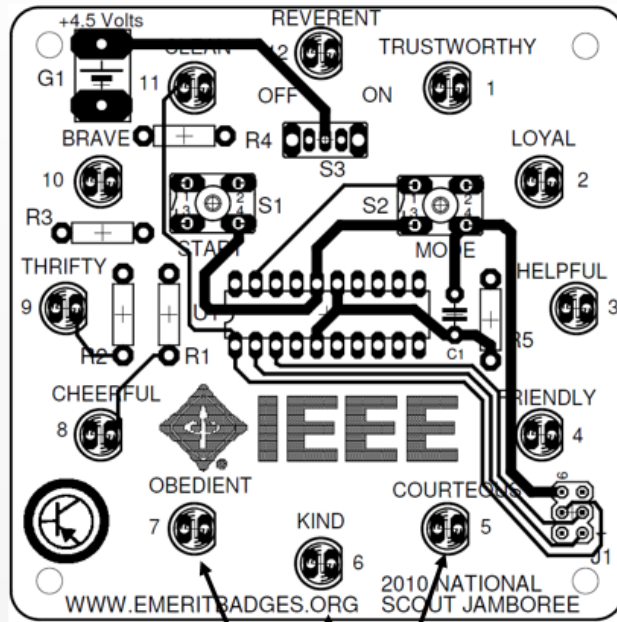

When soldering LED's, do not leave the solder iron on pads for more than 5 seconds, or you will destroy the pad.

- Place LED's on PC board, flat side of LED's facing right, bend leads out, then solder leads.
- After soldering, cut leads close to board.
- There are 12 of these.
 - Solder only 1 lead of each LED.
 - Place solder iron on soldered lead, melting solder, and then press LED flush to the board.
 - Then solder the other lead.

Microprocessor Controlled Counter Kit

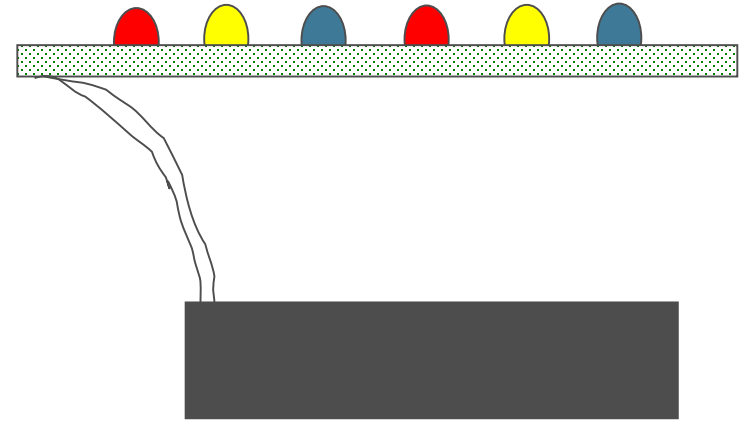
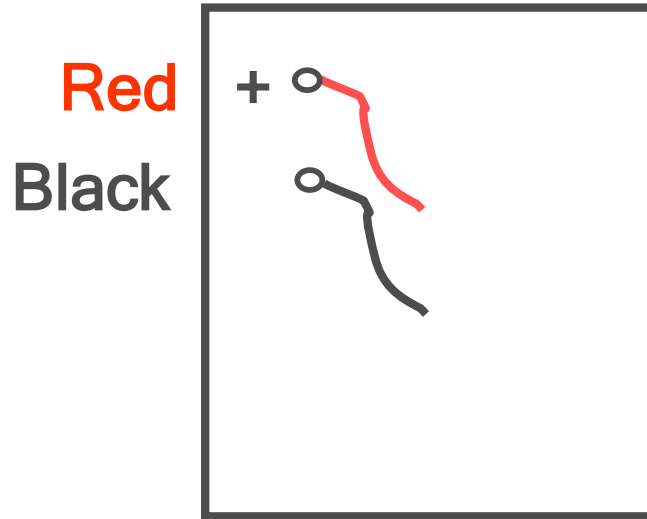

- From the bottom of the board, insert the red battery holder lead into the + hole.
- Insert the black lead into the other hole.
- From the top of the board, solder both battery leads.
- Inspect board for good solder joints and for no solder shorts.

Microprocessor Controlled Counter Kit

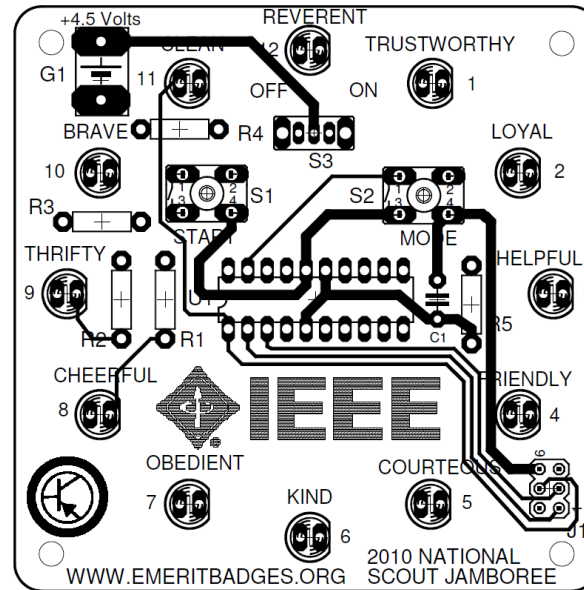

- Inspect board for good solder joints and for no solder shorts.
- Make sure resistors are in the right place.
- Make sure the LEDs are not in backwards.
- Insert the batteries into the battery holder. Be sure to get the polarity + and - correct.
- Slide S3 to ON.
- Push S1 to run.
- Push S2 for different program modes.
- If the kit does not work, have your merit badge counselor help you check it for problems.

Microprocessor Controlled Counter Kit

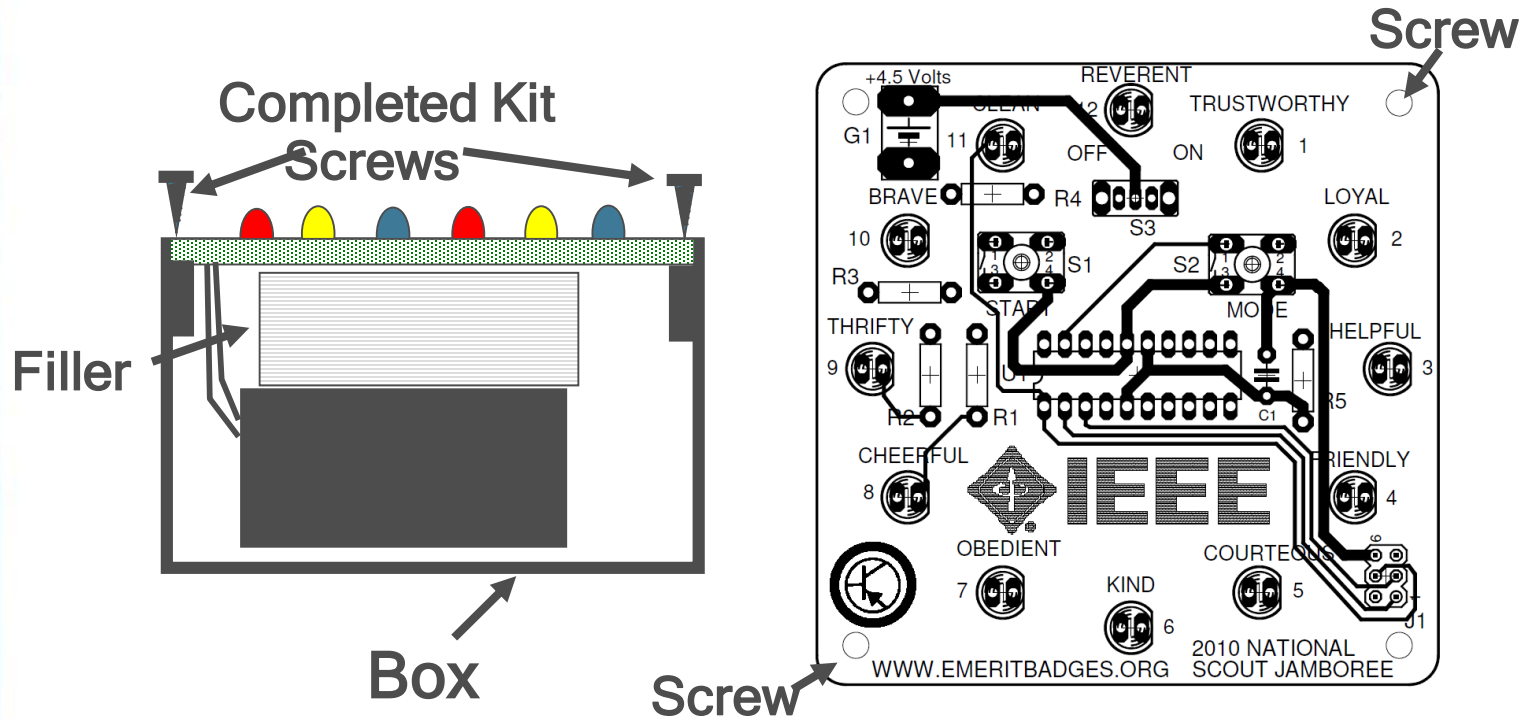

- Place the battery holder in the box.
- Place foam or wad of paper filler on top of the battery.
- Place the board onto the top of the box, and using the 2 screws, secure the board to the box.
- Place the screws in opposite corners.

Requirement 5



Do the following:

- Show how to solve a simple problem involving current, voltage, and resistance using Ohm's law.
- Tell about the need for and the use of test equipment in electronics. Name three types of test equipment. Tell how they operate.
- Demonstrate to your counselor how to read the colored bands of a resistor to determine its resistance value.

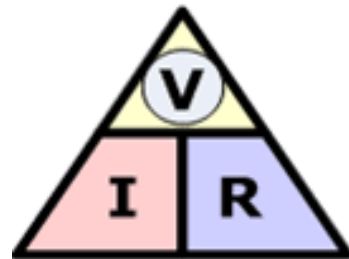

$$\textcircled{V} = I \times R$$

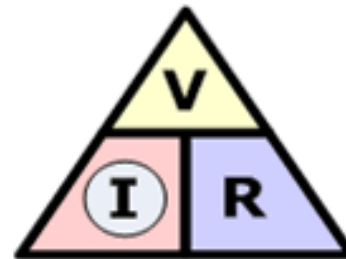

$$\textcircled{I} = \frac{V}{R}$$

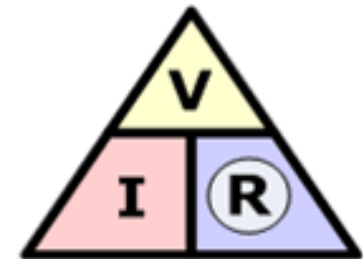

$$\textcircled{R} = \frac{V}{I}$$

Ohms Law

- Remember, if we know two of the values for Ohm's Law, we can solve for the third.

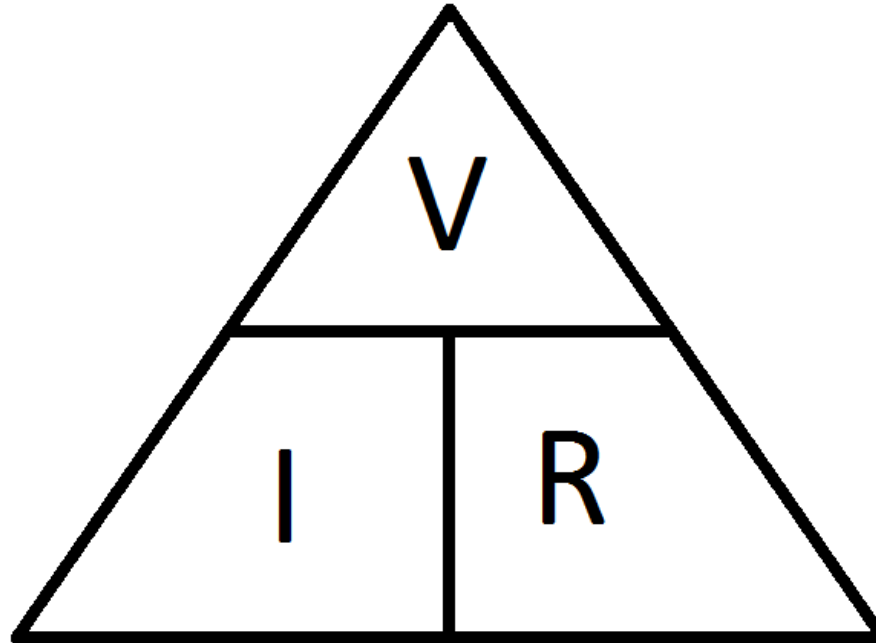

$$I = V/R$$

$$V = IR$$

$$R = V/I$$

- Download the **Ohms Law Practice Problems Worksheet** that accompanies this presentation and solve the problems.

Requirement 5



Do the following:

- Show how to solve a simple problem involving current, voltage, and resistance using Ohm's law.
- Tell about the need for and the use of test equipment in electronics. Name three types of test equipment. Tell how they operate.**
- Demonstrate to your counselor how to read the colored bands of a resistor to determine its resistance value.



Electronic Test Equipment

- Electronic test equipment includes the instruments that are used to diagnose the operation of electronic circuits.
- These instruments include:
 - Ammeters
 - Voltmeters
 - Ohmmeters
 - Multimeters
 - Oscilloscopes
 - Signal generators

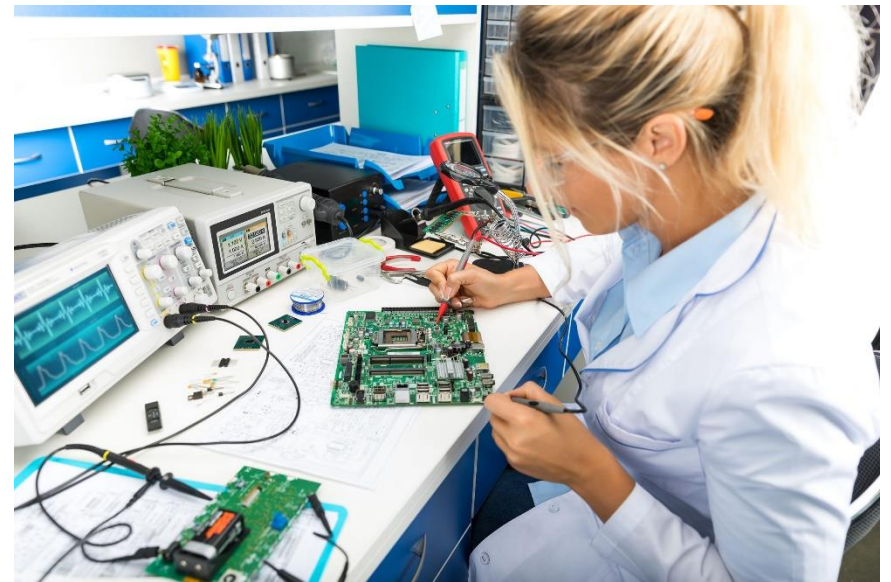

Ammeter

- An ammeter is a device or instrument that can measure either direct or alternating electric current in amperes that flow in an electric circuit.



Voltmeter

- A voltmeter, also known as a voltage meter, is an instrument that measures the voltage or potential difference between two points of an electronic or electrical circuit.
- It is used to test either alternating current (AC) or direct current (DC) circuits.
- It uses a scale that is commonly in volts, millivolts (0.001 volt), or kilovolts (1,000 volts).



Ohmmeter

- An ohmmeter is an electronic device that measures resistance in an electronic component or circuit.
- It works by using 2 probes to send a current through the circuit and measuring how much resistance, in ohms, that current encounters.

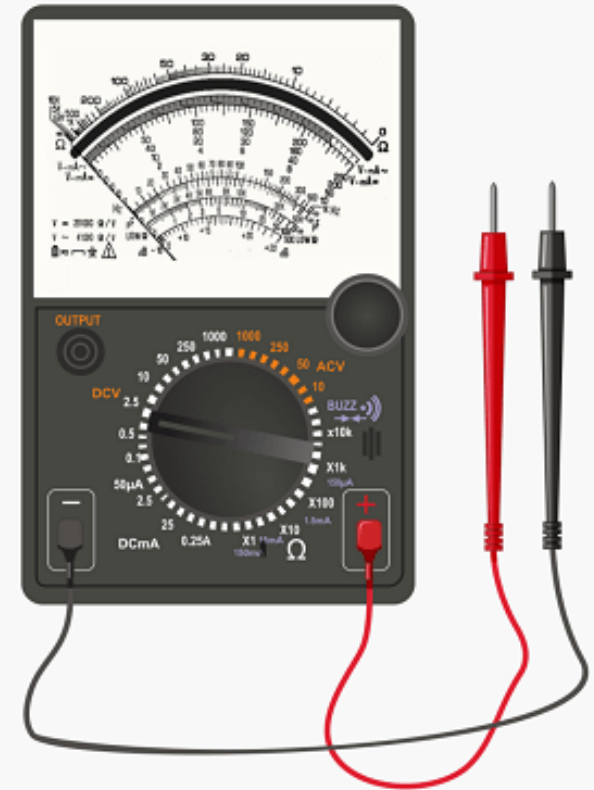

Multimeter

- A multimeter is a device used to measure multiple parameters of an electric circuit like voltage, current, and resistance.
- The device is made up of a digital or analog meter, batteries, resistors, and other circuitry, which ensure the measurement of several electrical quantities with very high accuracy and speed.



Oscilloscope

- An oscilloscope is an instrument that graphically displays electrical signals and shows how those signals change over time.
- Engineers use oscilloscopes to measure electrical phenomena and quickly test, verify, and debug their circuit designs.

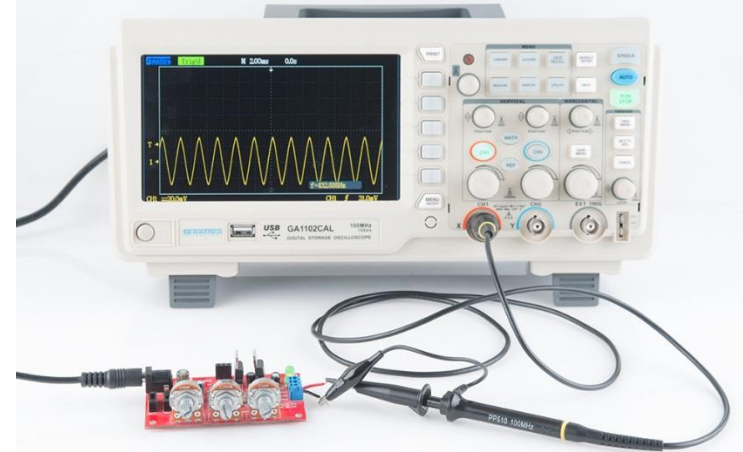

Signal Generator

- A signal generator is one of a class of electronic devices that generates electrical signals with set properties of amplitude, frequency, and wave shape.
- Signal generators are mostly used in designing, manufacturing, servicing and repairing electronic devices.



Requirement 5



Do the following:

- Show how to solve a simple problem involving current, voltage, and resistance using Ohm's law.
- Tell about the need for and the use of test equipment in electronics. Name three types of test equipment. Tell how they operate.
- Demonstrate to your counselor how to read the colored bands of a resistor to determine its resistance value.**



Three or Four Band Resistors

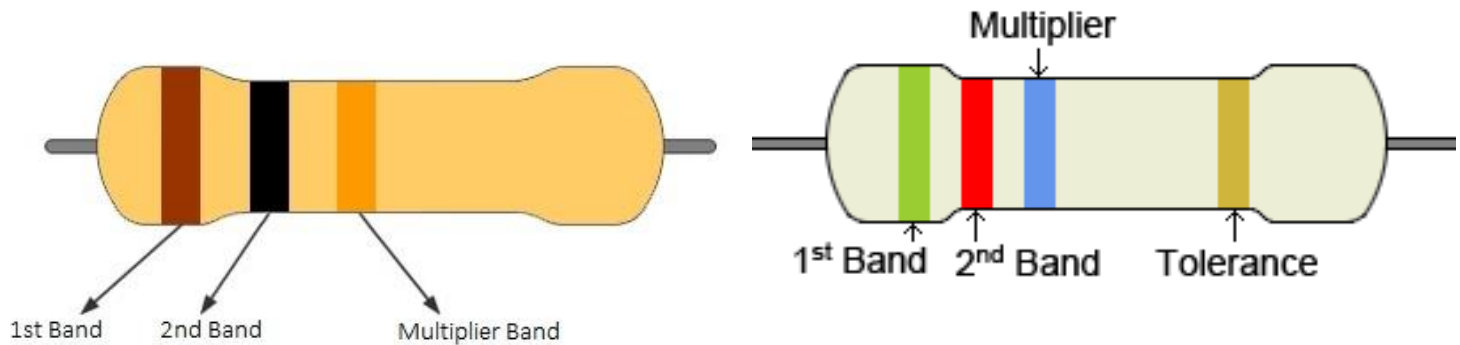

- The first two bands always denote the first two digits of the resistance value in ohms. On a three or four-band resistor, the third band represents the multiplier. This multiplier will basically shift your decimal place around to change your value from mega ohms to milliohms and anywhere in between. The fourth color band signifies tolerance. Keep in mind that if this band is absent and you are looking at a three-band resistor, the default tolerance is $\pm 20\%$.

Five or Six Band Resistors

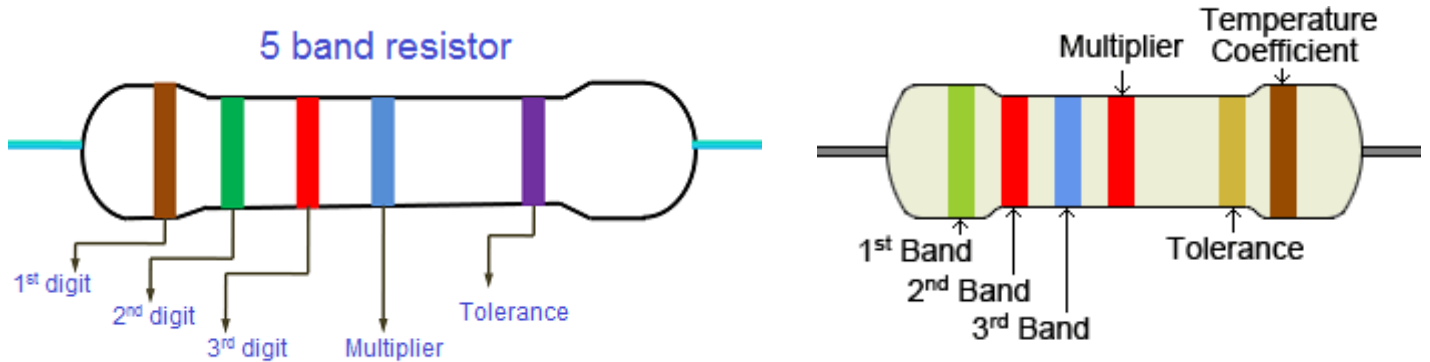

- Resistors with high precision have an extra color band to indicate a third significant digit. If your resistor has five or six color bands, the third band becomes this additional digit along with bands one and two. Everything else shifts to the right, making the fourth color band the multiplier and the fifth band the tolerance. A six-band resistor is basically a five-band type with an additional ring indicating the reliability, or the temperature coefficient (ppm/K) specification. Using brown, the most common sixth band color, as an example, every temperature change of 10°C changes the resistance value by 0.1%.

How to Read Resistor Color Codes

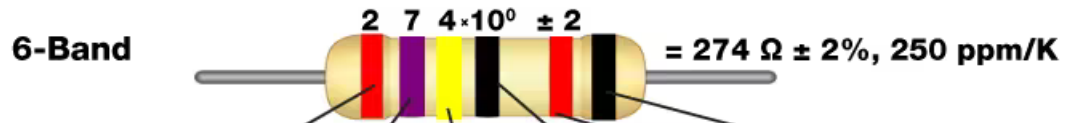

Color	1st Digit	2nd Digit	3rd Digit	Multiplier	Tolerance	Temperature Coefficient
Black	0	0	0	1 Ω		250 ppm/K
Brown	1	1	1	10 Ω	\pm 1%	100 ppm/K
Red	2	2	2	100 Ω	\pm 2%	50 ppm/K
Orange	3	3	3	1k Ω		15 ppm/K
Yellow	4	4	4	10k Ω		25 ppm/K
Green	5	5	5	100k Ω	\pm 0.5%	20 ppm/K
Blue	6	6	6	1M Ω	\pm 0.25%	10 ppm/K
Violet	7	7	7		\pm 0.1%	5 ppm/K
Grey	8	8	8			1 ppm/K
White	9	9	9			
Gold				0.1 Ω	\pm 5%	
Silver				0.01 Ω	\pm 10%	

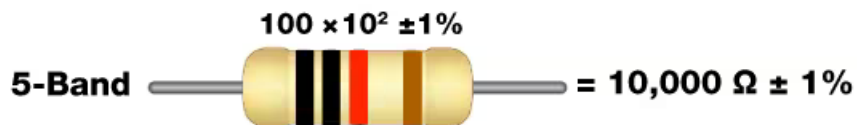
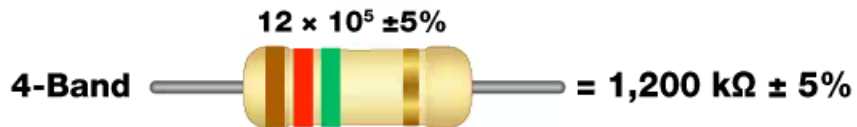

Requirement 6



Find out about three career opportunities in electronics that interest you. Discuss with and explain to your counselor what training and education are needed for each position.



Careers in Electronics



- A job in electronics refers to any job that involves working with technology or electrical components of machines, structures and devices.
- Many jobs in electronics are engineering positions that develop new types of machinery and equipment.
- However, there are also jobs in electronics for technicians, or people who perform repairs and maintenance on electronic devices.
- Electronics jobs typically pay competitive salaries and offer stable employment, as technology is always developing and providing new opportunities for work in the industry.

Computer Technician

- A computer technician installs and repairs computers and computer systems for businesses and organizations.
 - Computer technicians can also oversee cybersecurity efforts to protect their clients' data and internet use.
- Computer technicians typically possess a Bachelor's Degree in Information Technology, Computer Science or another closely related field.
 - Some employers may accept candidates who have an associate's degree.
- Employers also look for candidates who possess relevant certifications.
 - Companies may require individuals to have the A+ certification at a minimum, although some may require specific software certifications, including those offered by Microsoft.



Appliance Technician

- An appliance technician is primarily responsible for installing and repairing appliances in residential or commercial buildings.
 - This can involve inspecting appliances to determine the source of an issue, completing repairs with the necessary tools and parts and installing new appliances in homes, offices or other buildings.
 - Appliance technicians can work with many devices, such as washing machines, refrigerators, microwaves and ovens.
- Employers may look for candidates who possess relevant certifications or experience.
 - National Appliance Service Technician Certification (NASTeC) or state-issued appliance certification.



Electronics Technician

- An electronics technician is a catch-all term for people in charge of testing and repairing electronic devices or components.
 - In this career, you install and troubleshoot devices using tools like a multimeter or voltage tester.
 - If the circuit is faulty, you use tools like cable crimpers and soldering equipment to repair it.
 - You also have to complete the documentation of the testing procedures.
- To be an electronics technician, you need to have a bachelor's degree in electronic engineering or become an electrician apprentice.
 - Both routes give you the knowledge and experience necessary to perform repairs.

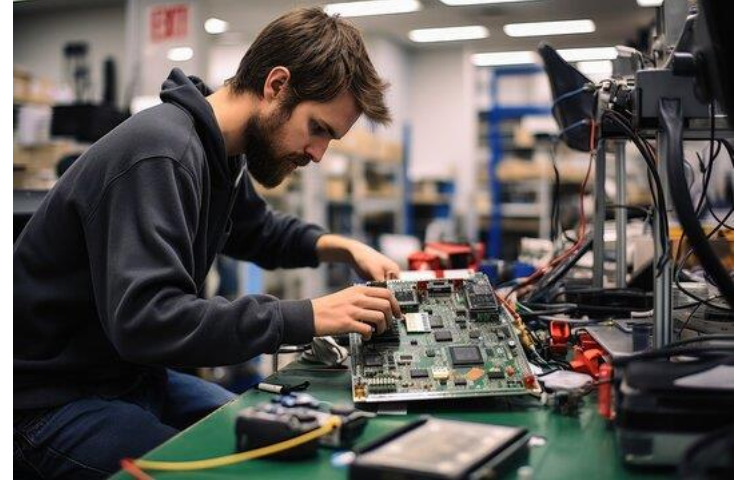

Avionics Specialist

- An avionics specialist often works in the aviation industry.
- As an avionics specialist, you have to maintain the components of a plane that rely on electricity to function.
 - This includes devices like radar, navigation equipment, lighting, tracking equipment, and environmental control.
 - You calibrate and install wiring, display panels, meters, and other electronic components that keep the craft running smoothly and safely.
- The qualifications for this job are a bachelor's degree in a relevant field, along with ample experience in the electronics field.



Audio Engineer

- An audio engineer uses sound equipment to produce the audio elements of recorded projects and live events.
 - This can involve monitoring the levels of microphones to ensure an audience can hear all live performers at a show, adding sound effects to video or film projects and mixing and producing songs for recording artists.
 - Audio engineers are also sometimes referred to as audio equipment technicians or sound technicians.
- Most employers require at least a certificate in audio engineering, and many may prefer a degree.
 - Degrees include associate and bachelor's degrees in audio engineering, music production and engineering, and sound design.
 - These programs combine technical and creative coursework with hands-on experience.



Electronics Engineer

- An electronics engineer specializes in designing and building new electronic equipment and devices.
 - This can involve designing software and computer systems for devices.
 - It may also include testing new electronic equipment to ensure it works effectively and developing applications for existing electronic devices.
 - Electronics engineers can work on products like cell phones, GPS devices, broadcasting systems and more.
- Electrical and electronics engineers typically need a bachelor's degree in electrical engineering, electronics engineering, or a related engineering field.

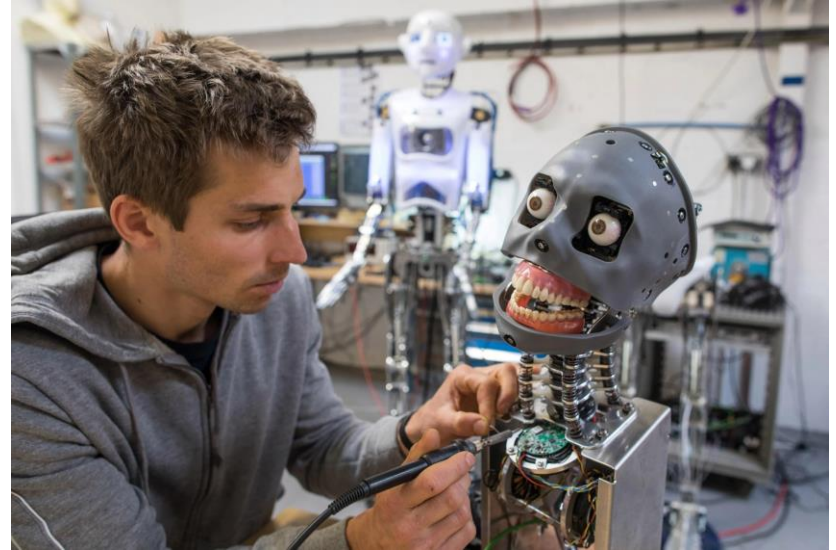

GAME OVER